

Quadrant Engineering Plastic Products

Global leader in engineering plastics for machining

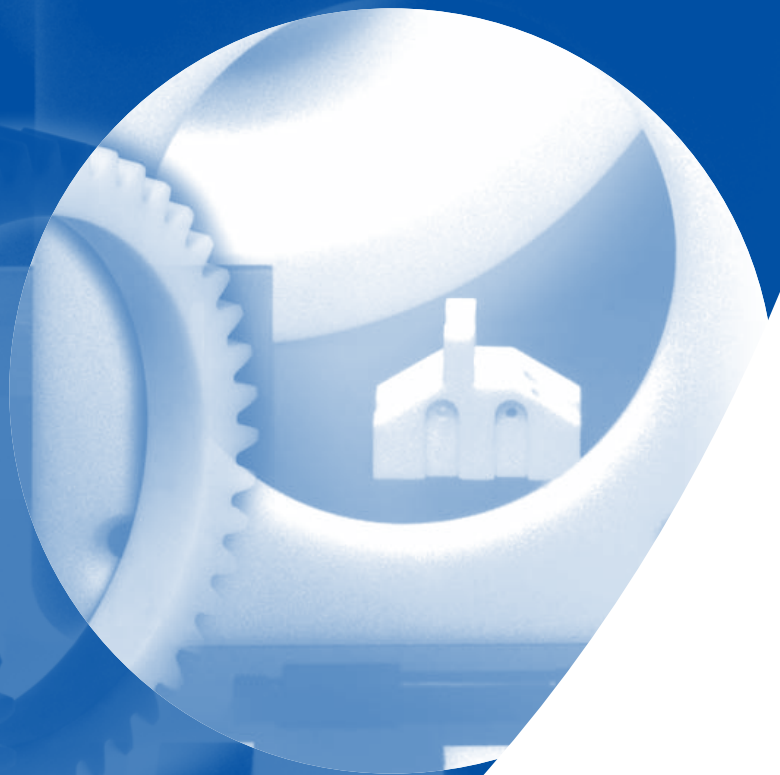

Design and Fabrication Reference Guide



QUADRANT

You inspire ... we materialize®

[PLASTICS OVERVIEW



→ **The World's Leading Manufacturer of Plastic Stock Shapes.**

The Quadrant Design & Fabrication Reference Guide was developed to assist materials specifiers, designers, and fabricators in the use of engineering plastics. Although the content of this guide is primarily intended to facilitate the use of engineering plastic stock shapes for machined parts, much of the information presented here may be applied to plastic parts processed via alternative methods such as injection molding.

This reference is divided into four sections. The first section provides an overview of plastics as engineering materials, basic design considerations, and an introduction to commonly used physical properties.

The material selection section is a step-by-step guide to selecting plastics based upon specific application requirements, including the need for chemical resistance and FDA, or other regulatory agency approval. The component design section contains guidelines for designing plastic bearings, wheels, sheaves and gears. The final section discusses fabrication guidelines to facilitate machining of plastic stock shapes, and answer frequently asked fabrication questions.

This brochure does not include detailed Quadrant product descriptions or physical property data. That information is contained in our *Product and Applications Guide, (LIT.Quadrant)* which may be requested by contacting Quadrant at 1-800-366-0300, or on our website at www.quadrantplastics.com.

Plastics increasingly replace traditional materials such as bronze, stainless steel, cast iron and ceramics. They are chosen for improved performance and cost reduction. Plastics can:

- Reduce Weight
- Eliminate Corrosion
- Improve Wear Performance in Unlubricated Conditions
- Reduce Noise
- Increase Part Life
- Insulate & Isolate, Both Thermally and Electrically

A comparison of typical properties for common engineering materials is shown in Table 1.

Typical applications for engineering plastics range from semiconductor processing equipment components to heavy equipment wear parts, to food processing industry components.

Machinable plastic stock shapes (sheet, rod, and tubular bar) are now available in more than 50 grades, spanning the performance/price range of both ferrous and non-ferrous metals to specialty ceramics. Plastics capable of long term service up to 800°F (425°C), with short term exposures to 1,000°F (540°C) are now available. As the number of material options has increased, so has the difficulty of selecting the right material for a specific application. This overview will help you understand basic categories of plastic materials.

The Materials Positioning Triangle shown on page 4 (Figure 1) includes the most common thermoplastics grouped according to general performance characteristics. Materials within a specific group have similar general characteristics as defined by the group positioning statement. The materials are ranked according to heat resistance.

Table 1 : Typical Properties of Engineering Materials

Property	Units	Nylatron® PA	Duratron® PAI	Bronze	Steel (A36)	Aluminum
Density	g/cm ³	1.15	1.41	8.80	7.84	2.70
Tensile Strength	psi	12,000	20,000	22,000	36,000	30,000
Modulus of Elasticity	psi	0.4 x 10 ⁶	0.6 x 10 ⁶	16 x 10 ⁶	30 x 10 ⁶	10 x 10 ⁶
Relative Strength to Weight	Steel = 1.0	2.27	2.78	0.54	1.0	2.41
Coefficient of Linear Thermal Expansion	in./in./°F	50 x 10 ⁻⁶	17 x 10 ⁻⁶	10 x 10 ⁻⁶	6.3 x 10 ⁻⁶	12 x 10 ⁻⁶

Dark blue columns are plastics.

[TABLE OF CONTENTS



TABLE OF CONTENTS

PLASTICS OVERVIEW

p. 2

CHEMICAL RESISTANCE DATA

p. 32

**DESIGNING WITH PLASTICS-
PROPERTY BASICS**

p. 6

**PRODUCT COMPLIANCE /
REGULATORY INFORMATION**

p. 36

MATERIAL SELECTION

p. 12

FABRICATION GUIDELINES

p. 38

COMPONENT DESIGN

POST MACHINING ANNEALING

p. 43

BEARING DESIGN

p. 16

ROLLER / WHEEL DESIGN

p. 21

SHEAVE DESIGN

p. 24

GEAR DESIGN

p. 28

Thermoplastics and Thermosets

Plastics are commonly described as being either a thermoplastic (meltable) or a thermoset (non meltable). Thermoset materials such as phenolic and epoxy were developed as early as 1900 and were some of the earliest "high volume" plastics. Both thermoplastic and thermoset stock shapes are available for machined parts, although thermoplastic stock shapes are much more commonly used today. Their ease of fabrication, self-lubricating characteristics, and broad size and shape availability make thermoplastics ideal for bearing and wear parts as well as structural components.

WE'RE READY TO HELP.

If you have any questions regarding information in this brochure, contact us:

Tech Service: 800.366.0300

Website: www.quadrantplastics.com



PLASTICS OVERVIEW

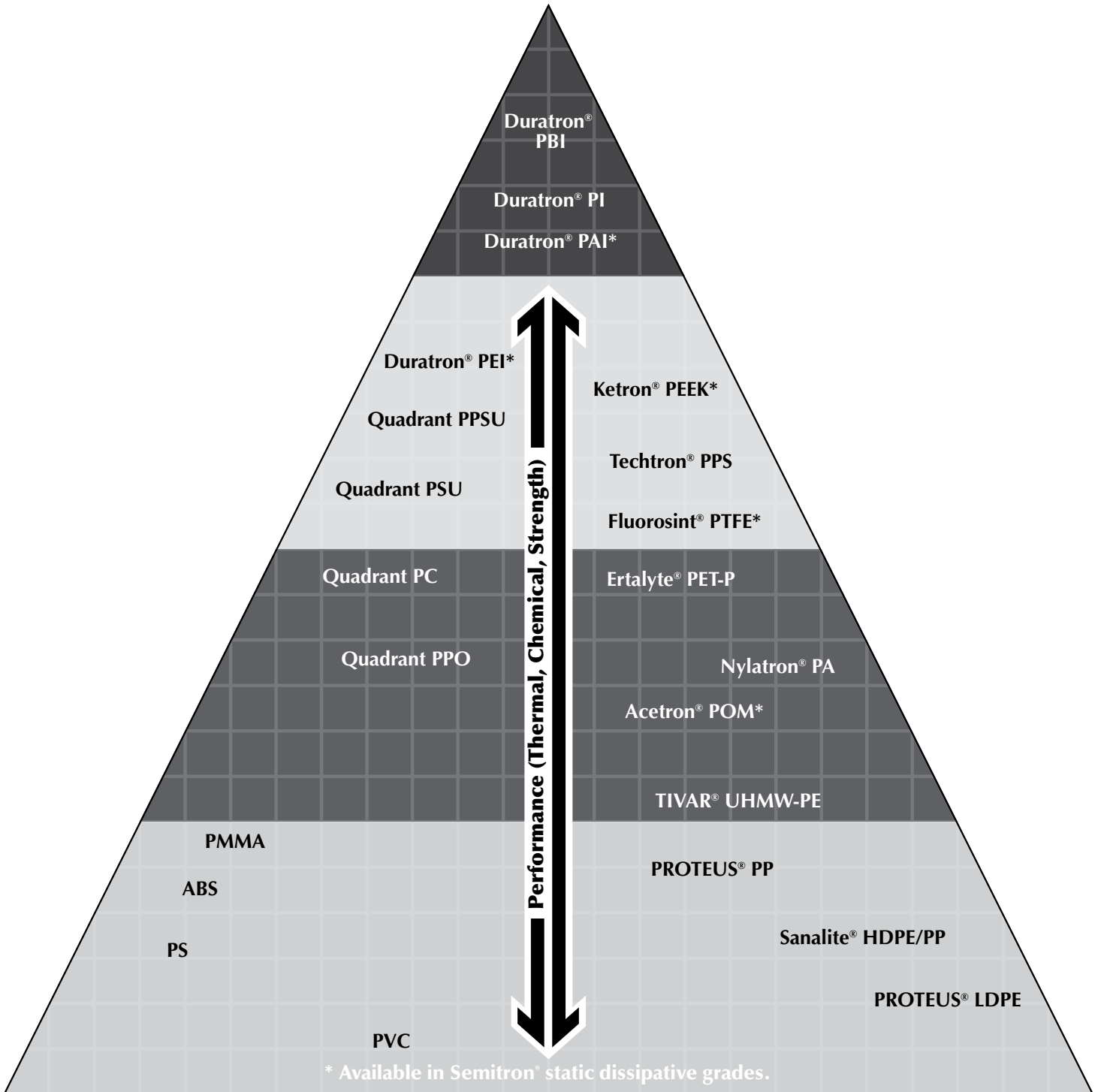

Performance Family	Material	Tradename	Performance Profile
Advanced Engineering Plastics	Imidized	Duratron® PBI Duratron® PI Duratron® PAI Ketrion® PEEK Techtron® PPS Fluorosint® PTFE	Highest heat resistance and strength High heat resistance to 600°F Highest strength to 500°F, dimensionally stable Chemical, wear and heat resistance Chemical resistance, strength, and wear resistance Chemical resistance and dimensional stability
	Crystalline High Performance	Filled Polytetrafluoroethylene (PTFE) Polyetherimide (PEI)	High strength and heat resistance to 400°F High strength, steam and impact resistance
	Amorphous High Performance	Polyphenylsulfone (PPSU) Polysulfone (PSU)	High strength and heat resistance to 300°F
Engineering Plastics	Crystalline Engineering	ErtalMe® PET-P Acetron® POM MC® or Nyatron®	Dimensional stability and wear resistance Machinability and dimensional stability Toughness, wear resistance and strength
	Amorphous Engineering	TIVAR® UHMW-PE Quadrant PC 1000 Quadrant PPO	Toughness and abrasion resistance Impact and heat resistance to 250°F Heat resistance, toughness and thermoformability Clarity and formability
Standard Plastics	Acrylonitrile butadiene styrene (ABS) Polystyrene (PS) Polyvinyl chloride (PVC) Polypropylene (PP) High Density Polyethylene (HDPE) Low Density Polyethylene (LDPE)	Quadrant PVC PROTEUS® PP PROTEUS® HDPE PROTEUS® LDPE	Medium strength, toughness and thermoformability Rigid, Light weight, thermoformable Light weight, easily processed Chemical resistance, medium strength Chemical resistance, low cost Chemical resistance, formability, low cost

Table 2

[DESIGNING WITH PLASTICS

Designing machined plastic components follows the approach used for metals but requires special consideration of:

- **Elastic Behavior**
- **Impact Strength**
- **Thermal Properties**
- **Dimensional Stability**

ELASTIC BEHAVIOR

The stress/strain behavior of a plastic differs from that of a metal in several respects as can be seen in Figure 2.

- **The yield stress is lower**
- **The yield strain is higher**
- **The slope of the stress/strain curve may not be constant below the yield point**

The modulus as determined using standard tests is generally reported as the ratio of stress to strain at the origin of loading up to 0.2% strain.

The effects of time, temperature and strain rate generally require consideration due to the viscoelasticity of plastics. Strains below 1% remain within the elastic limits of most engineering plastics and therefore allow analysis based upon the assumption the material is linearly elastic, homogeneous, and isotropic. Another common practice is to design components so that the maximum working stress is 25% of the material's strength. This also minimizes plastics' time-dependent stress/strain behavior.

IMPACT STRENGTH

Although a number of plastics are well suited for high impact applications, most parts made from rigid engineering plastics require minor design modifications. Sharp interior corners, thread roots and grooves should be broadly radiused (0.040" min.) to minimize the notch sensitivity of these materials. The relative notch sensitivity or impact resistance of plastics is commonly reported using Izod impact strength. Materials with higher Izod impact strengths are more impact resistant.

THERMAL PROPERTIES

Two important thermal properties for designing plastic components are:

- **Continuous Service Temperature -** the temperature above which significant and permanent degradation of the plastic occurs with long exposure.
- **Heat Deflection Temperature -** the softening temperature of a plastic as defined by the ASTM test method (D 648). It is commonly referred to as the maximum service temperature for a highly stressed, unconstrained component.

Note: The strength and stiffness of plastics can be significantly affected by relatively small changes in temperature. Dynamic Modulus Analysis (DMA) curves can be used to predict the effects of temperature change on a given material.

Fig. 2 - **STRESS VS. STRAIN**

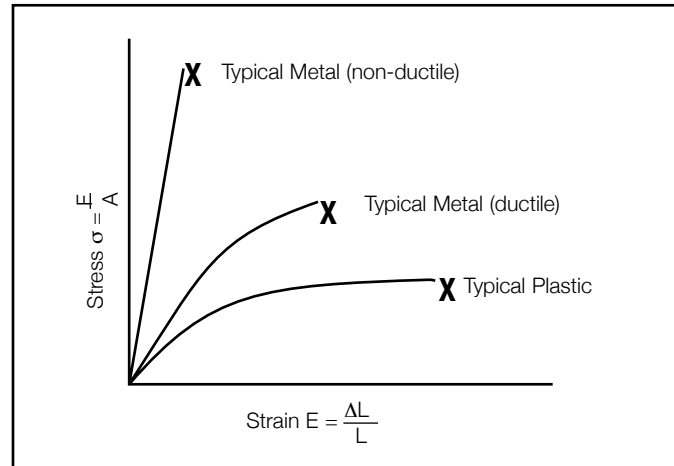

DIMENSIONAL STABILITY

Plastics expand and contract 10 times more than many metals. A material's dimensional stability is affected by temperature, moisture absorption and load. Assemblies, press fits, adhesive joints and machined tolerances must reflect these differences. Certain plastics such as nylons are hygroscopic – absorbing up to 8% water (by weight, when submerged). This can result in a dimensional change of up to 3%. Plastics' inherently lower modulus of elasticity can also contribute to dimensional change including part distortion during and after machining.

The following five pages provide an introduction to common physical properties and terms used to characterize materials and design plastic components. Physical property values for specific materials can be found in our *Products and Applications Guide (LIT.Quadrant)*.

PROPERTY BASICS

Tensile Strength (ASTM D 638)

Ultimate tensile strength is the force per unit area required to break a material under tension. It is expressed in pounds per square inch (psi). The force required to pull apart 1 square inch of plastic may range from 1,000 to 50,000 lbs. or higher. Steel and other structural alloys have much higher tensile strengths, such as SS304 at 84 kpsi. A test schematic is shown in Figure 3.

Elongation (ASTM D 638)

Elongation (which is always associated with tensile strength) is the increase in length at fracture, expressed as a percentage of original length. For example, a strip of writing paper can be pulled apart with almost no visual stretching or elongation. On the other hand, a rubber band may be stretched several times its original length before breaking.

DESIGN TIP

Tensile strength and elongation are both important when toughness is required. A material with high tensile and high elongation such as Quadrant PPSU, is a tougher material than one having a high tensile/low elongation.

Compressive Strength (ASTM D 695)

Compressive strength measures a material's ability to support a compressive force. Figure 4 details a test schematic. Always reported as pounds per square inch (psi), this property may indicate one of the following:

- **ultimate compressive strength** (the maximum stress to rupture a test sample)
- **compressive strength at a specific deformation** (i.e. 0.1%, 1%, 10% – typically used for materials like plastics that may not rupture)
- **compressive yield strength** (the stress in psi as measured at the point of permanent yield, zero slope, on stress-strain curve)

Flexural Strength (ASTM D 790)

Flexural properties measure a material's resistance to bending under load. The load at yield is the flexural strength of the material and is typically expressed in psi. For plastics, the data is usually calculated at 5% deformation/strain (the loading necessary to stretch the outer surface 5%). See Figure 5 for test illustration.

Hardness

Hardness is usually reported by one of two test methods – Rockwell (ASTM D 785) or Indentation Hardness/Durometer (ASTM D 2240). The Rockwell test is typically chosen for hard materials such as acetal, nylon, and PEEK where creep is less of a factor in the test results. A test schematic is shown in Figure 6.

Fig. 3

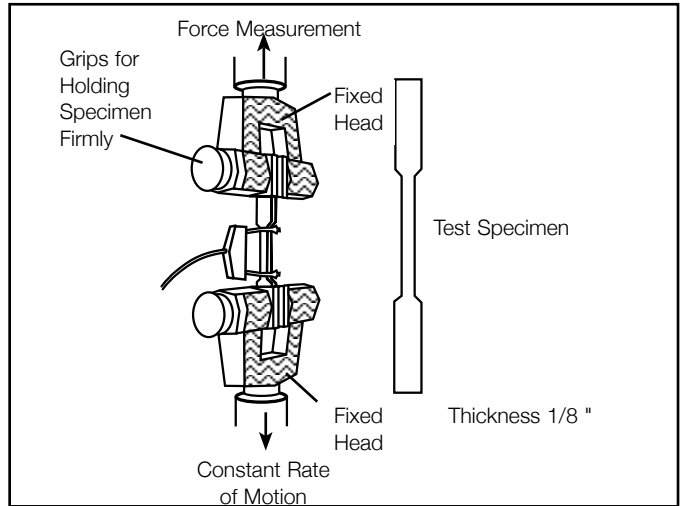

ASTM D 638: For this test, samples are either machined from stock shapes or injection molded. The tensile testing machine pulls the sample from both ends and measures the force necessary to pull the specimen apart (Tensile Strength), and how much the material stretches before breaking (Elongation).

Fig. 4

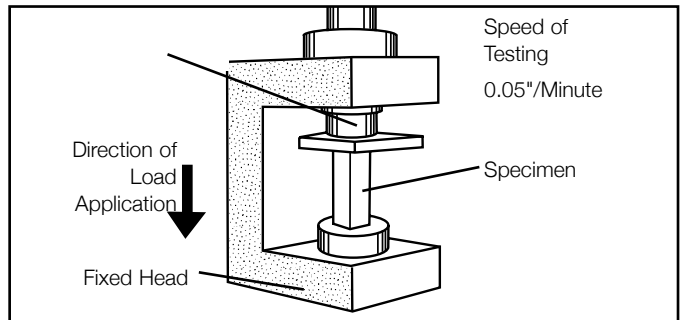

ASTM D 695: Specimen of 1/2" x 1/2" x 1" is mounted in a compression tool between testing machine heads. An indicator registers the load in psi.

Fig. 5

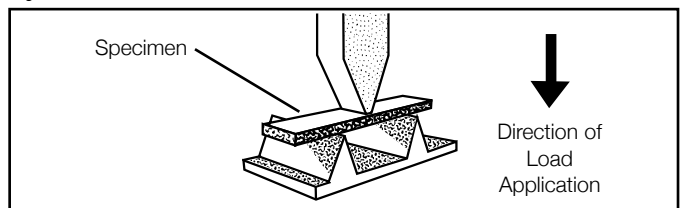

ASTM D 790: Specimen of 1/8" x 1/2" x 5" is placed on two supports and a load is applied in the center. The load at yield is a material's flexural strength.

Fig. 6

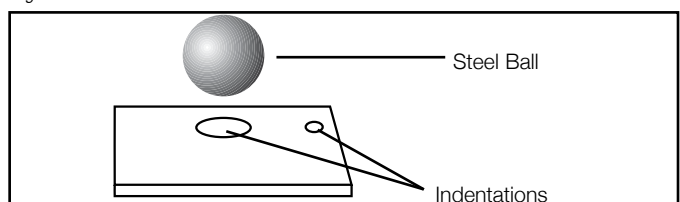

PROPERTY BASICS

The Durometer is reported for softer materials such as Urethane and PVC. The two scales do not correlate and cannot be compared. Hardness data is best used to compare materials. By itself the test is no indication of strength, wear performance or abrasion resistance.

Modulus (Tensile, Compressive, Flexural)

The modulus of elasticity (tensile, compressive or flexural) relates an applied stress to a resultant strain. Since all plastics do not exhibit perfect elasticity upon loading (a defined constant slope as part of their stress/strain curve), a tangent modulus is generally reported.

Due to plastics' time dependent (viscoelastic) behavior under stress, special consideration must be given when designing for continuous or long-term applied stresses. When time dependent strains must be determined, apparent modulus (creep) values must be used. These data are both time and temperature dependent and generally developed using a DMA (Dynamic Modulus Analyzer). DMA curves for Quadrant materials can be found on page 9, 10 and 11 of the *Products and Applications Guide*.

Impact/Toughness

A material's ability to absorb rapidly applied energy is its impact resistance. Impact resistance will vary based upon the shape, size, thickness, and type of material. Various methods of impact testing do not provide results that are of immediate use to a designer, but are very helpful when comparing the relative impact resistance of various materials. The impact tests most frequently used are Izod and Tensile impact. Charpy and Gardner impact tests can also be used to get a complete characterization of a material's toughness.

IZOD IMPACT (ASTM D 256)

One of the most widely used methods for measuring impact strength is the Izod impact test. In this test, a pendulum arm swings to impact a notched, cantilevered beam (See Figure 7). After fracturing the test specimen, the pendulum continues to travel in the same direction, but with less energy due to the impact with the specimen. This loss of energy, measured in foot-pounds per inch (ft-lb/in., or J/m) of beam thickness, is known as the Izod impact strength. This test can also be done with either a notched or an unnotched specimen or with the notch reversed, in which case it is reported as "unnotched" or "reversed notch Izod" impact strength, respectively.

TENSILE IMPACT (ASTM D 1822)

This test uses a swinging pendulum similar to that used in the Izod impact test, except the sample specimen is a tensile bar. It is mounted, as shown in Figure 8, to measure the energy required to fracture it (pull it apart) due to rapid tensile loading.

Fig. 7 - IZOD IMPACT TEST

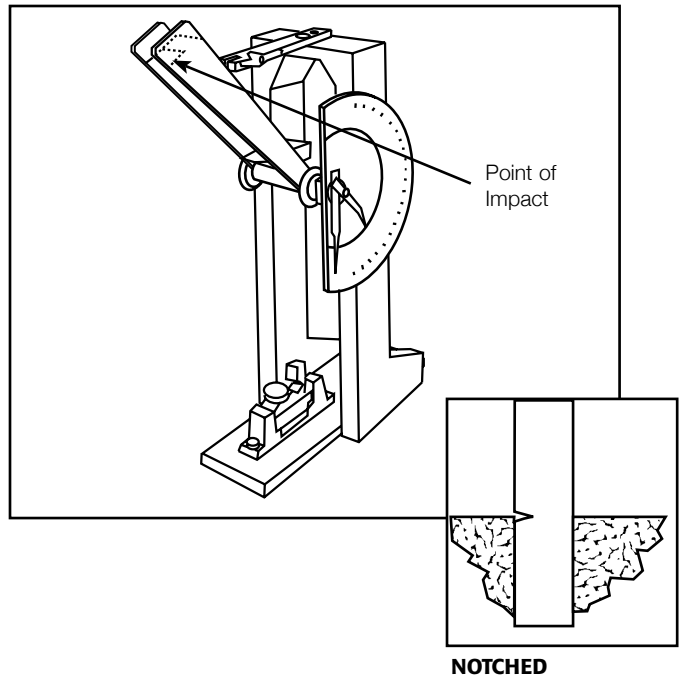
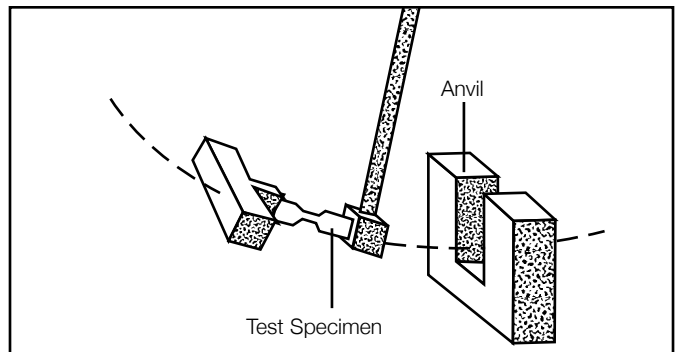

Fig. 8 - TENSILE IMPACT TEST



PROPERTY BASICS

Coefficient of Linear Thermal Expansion (E 831 TMA)

The coefficient of linear thermal expansion (CLTE) is the ratio of the change in a linear dimension to the original dimensions of the material for a unit change of temperature. It is usually measured in units of in./in./°F. CLTE is a very important consideration if dissimilar materials are to be assembled in applications involving large temperature changes. A thermoplastic's CLTE can be decreased (making it more dimensionally stable) by reinforcing it with glass fibers or other additives. The CLTE of plastics vary widely. The most stable plastics approach the CLTE of aluminum but exceed that of steel by up to ten times.

Heat Deflection Temperature (ASTM D 648)

The heat deflection temperature is the temperature at which a 1/2" thick test bar, loaded to a specified bending stress, deflects by 0.010 in. (see Figure 9). It is sometimes called the "heat distortion temperature" (HDT). This value is used as a relative measure of the ability of various materials to perform at elevated temperatures short term, while supporting loads.

Fig. 9

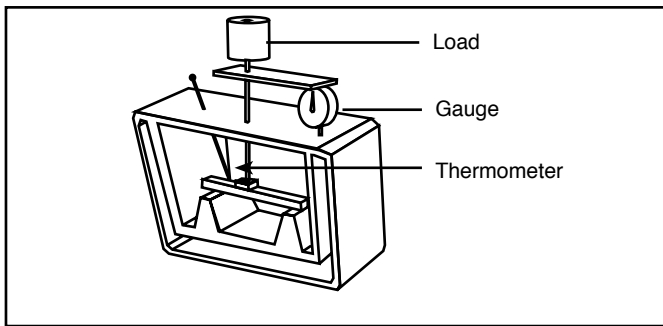

Continuous Service Temperature

This value is most commonly defined as the maximum ambient service temperature (in air) that a material can withstand and retain at least 50% of its initial physical properties after long term service (approximately 10 years). Most thermoplastics can withstand short-term exposure to higher temperatures without significant deterioration. When selecting materials for high temperature service both HDT and continuous service temperature need to be considered.

Tg (ASTM D 3418)

The glass transition temperature, Tg, is the temperature above which an amorphous polymer becomes soft and rubbery. Except when thermoforming, it is important to ensure that an amorphous polymer is used below its Tg if reasonable mechanical performance is expected.

Melting Point (ASTM D 3418)

The temperature at which a crystalline thermoplastic changes from a solid to a liquid.

Fig. 10 - RESISTIVITY CONTINUUM

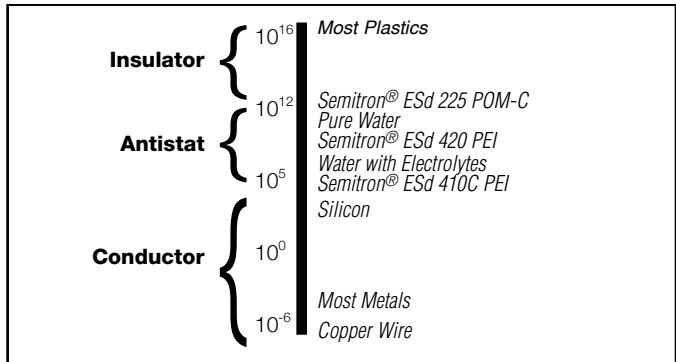
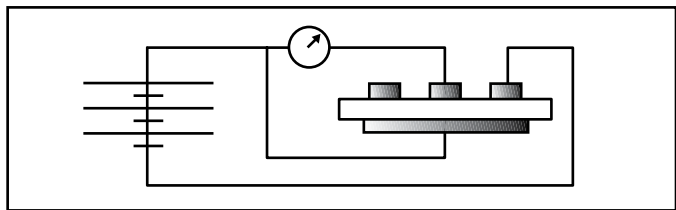

Fig. 11 - SURFACE RESISTIVITY



Volume Resistivity (ASTM D 257)

The volume resistivity of a material is its ability to resist the flow of electricity, expressed in ohms-cm. The more readily the current flows, the lower the volume resistivity. Volume resistivity can be used to predict the current flow from an applied voltage as demonstrated by Ohm's Law.

$$V = IR$$

Where:

V = Applied voltage (volts)

I = Electrical current (Amperes)

R = Resistance of the wire (ohms)

As the Resistivity Continuum in Figure 10 indicates:

- insulators exhibit resistivities of 10¹² and higher
- antistatic/partially conductive products exhibit resistivities of 10⁵ to 10¹²
- conductive products exhibit resistivities of 10⁻⁶ to 10⁵

For details concerning Quadrant's line of static dissipative plastics, please consult the *Advanced Engineering Plastics for the Semiconductor Industry brochure*.

Surface Resistivity (EOS/ESD S11.11)

This test measures the ability of current to flow over the surface of a material. Unlike the volume resistivity test, the test electrodes are both placed on the same side of the test specimen (see Figure 11). However, like volume resistivity, surface resistivity is affected by environmental changes such as moisture absorption. Surface resistivity is used to evaluate and select materials for testing when static charge dissipation or other surface characteristics are critical.

PROPERTY BASICS

Dielectric Strength (ASTM D 149)

When an insulator is subjected to increasingly high voltages, it eventually breaks down and allows a current to pass. The voltage reached before break down divided by the sample thickness is the dielectric strength of the material, measured in volts/mil. It is generally measured by putting electrodes on either side of a test specimen and increasing the voltage at a controlled rate (see Figure 12). Factors that affect dielectric strength in applications include: temperature, sample thickness, conditioning of the sample, rate of increase in voltage, and duration of test. Contamination or internal voids in the sample also affect dielectric strength.

Fig. 12

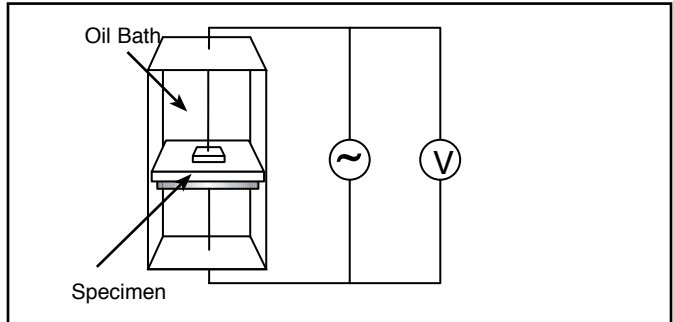

DESIGN TIP

Duratron® U1000 PEI has the highest short term dielectric strength of Quadrant's engineering plastics. The value is 830 Volts/mil. For more information concerning Duratron® U1000's electrical performance, see page 42 of Quadrant's *Products and Applications Guide*.

Dielectric Constant (ASTM D 150⁽²⁾)

The Dielectric Constant, or permittivity, is a measure of the ability of a material to store electrical energy. Polar molecules and induced dipoles in a plastic will align themselves with an applied electric field. It takes energy to make this alignment occur. Some of the energy is converted to heat in the process. This loss of electrical energy in the form of heat is called dielectric loss, and is related to the dissipation factor. The rest of the electrical energy required to align the electric dipoles is stored in the material. It can be released at a later time to do work.

The higher the dielectric constant, the more electrical energy can be stored. A low dielectric constant is desirable in an insulator, whereas someone wanting to build a capacitor will look for materials with high dielectric constants. Dielectric constants are dependent on frequency, temperature, moisture, chemical contamination and other factors. The values stated in Quadrant's literature are measured at 10⁶ Hertz in carefully conditioned samples.

Dissipation Factor (ASTM D 150)

The dissipation factor, or dielectric loss tangent, indicates the ease with which molecular ordering occurs under an applied voltage. It is most commonly used in conjunction with dielectric constant to predict power loss in an insulator.

Flammability

In electrical applications (or any applications where plastic constitutes a significant percentage of an enclosed space), the consequences of exposure to an actual flame must be considered (i.e. plastic panels used in the interior of an aircraft cabin). Flammability tests measure combustibility, smoke generation, and ignition temperatures of materials.

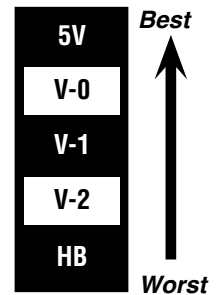

UL 94 FLAMMABILITY CLASS (HB, V-2, V-1, V-0, 5V)

In this test, specimens are subjected to a specified flame exposure. The relative ability to continue burning after the flame is removed is the basis for classification. In general, the more favorable ratings are given to materials that extinguish themselves rapidly and do not drip flaming particles. Each rating is based on a specific material thickness (i.e. UL94-V1 @ 1/8" thick). The UL rating scale from highest burn rate to most flame retardant is HB, V-2, V-1, V-0, 5V.

PROPERTY BASICS

Specific Gravity (ASTM D 792)

Specific gravity is the ratio of the mass of a given volume of material compared to the mass of the same volume of water, both measured at 73°F (23°C). (Density of a material divided by the density of water.) Since it is a dimensionless quantity, it is commonly used to compare materials. Specific gravity is used extensively to determine part cost and weight.

DESIGN TIP

Materials with specific gravities less than 1.0 (such as polyethylene and polypropylene) float in water. This can help with identification of an unknown plastic.

Water Absorption (ASTM D 570)

Water absorption is the percentage increase in weight of a material due to absorption of water. Standard test specimens are first dried then weighed before and after immersion in 73°F (23°C) water. Weight gain is recorded after 24 hours, and again when saturation is reached. Both percentages are important since they reflect absorption rate. Mechanical and electrical properties, and dimensional stability are affected by moisture absorption.

Coefficient of Friction (ASTM D 3702)

Coefficient of friction (COF) is the measure of resistance to the sliding of one surface over another. Testing can be conducted in a variety of ways although thrust washer testing is most common (See Figure 13). The results do not have a unit of measure associated with them since the COF is the ratio of sliding force to normal force acting on two mating surfaces. COF values are useful to compare the relative “slickness” of various materials, usually run unlubricated over or against polished steel. Since the value reflects sliding resistance, the lower the value, the “slicker” the bearing material.

Two values are usually given for COF.

- “Static” COF refers to the resistance at initial movement from a bearing “at rest”.
- “Dynamic” COF refers to the resistance once the bearing or mating surface is in motion at a given speed.

DESIGN TIP

The difference between the static and dynamic COF’s indicates “slip-stick”. A large difference indicates high slip-stick, and a low (or no) difference indicates low slip-stick. Slip-stick characteristics are important for applications which move intermittently, or require a back-and-forth motion. For a low slip-stick plastic, look to Nylatron® GSM Blue PA6 and Nylatron® 703XL PA6.

PV and Limiting PV

Two factors that must be considered when reviewing a bearing application:

- the load the bearing will be subjected to (measured as pressure=P (lbs./in.²))
- the speed of the contact surfaces (velocity=V (ft./min.))

The result of multiplying P by V is referred to as the PV for a bearing application. The combination of pressure and velocity causes the generation of frictional heat at the bearing surface. This heat can contribute to premature bearing failure due to overheating if an application PV exceeds the capability of a plastic bearing material.

Limiting PV is the maximum PV to which a bearing material should be subjected in unlubricated conditions. A material subjected to a PV in excess of its Limiting PV may fail prematurely due to surface melting or excessive wear.

Wear Resistance / “k” Factor

The wear factor (“k” factor) relates bearing surface wear rate to the variables of pressure, velocity and time.

$$“k” = \frac{\text{wear}}{\text{PVT}} \times 10^{10}$$

or wear (in.) = (k) PVT × 10⁻¹⁰

The lower the “k” factor, the greater the wear resistance. Results from this test can vary significantly if different pressure and velocity conditions are used. Consistency of test methods is critical if “k” factors are used to compare various materials.

DESIGN TIP

Enhanced bearing and wear materials, such as Nylatron® NSM PA6 nylon, combine a low wear rate (12) with high limiting PV capabilities (15,000 psi-ft./minute dry) – allowing much wider design flexibility and greater safety factors.

Fig. 13

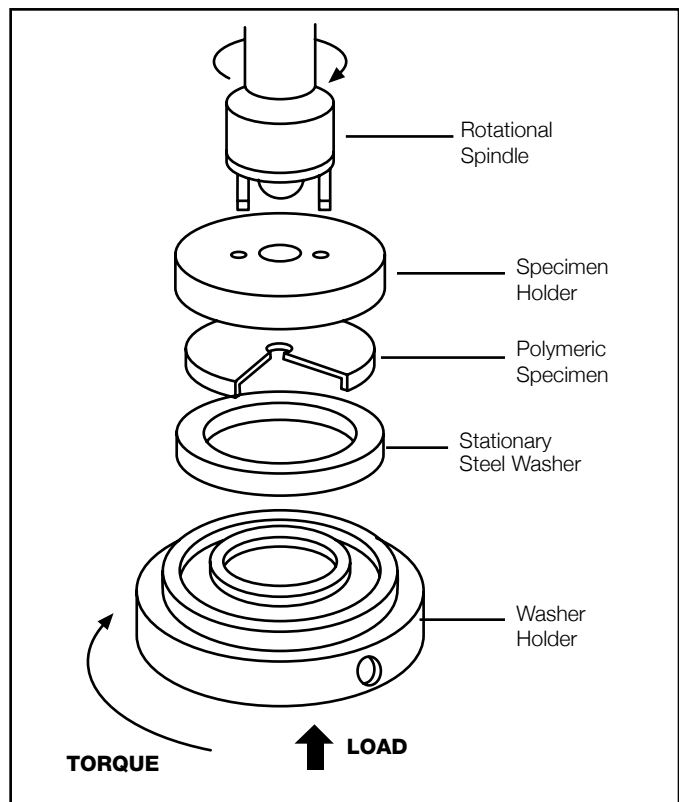

[MATERIAL SELECTION

STRUCTURAL

<input type="checkbox"/> Duratron® CU60 PBI	650°F
<input type="checkbox"/> Duratron® 7000 PI (D7000, D7015G)	500°F
<input type="checkbox"/> Fluorosint® PTFE	500°F
<input type="checkbox"/> Duratron® PAI Grades (T4203, T4503, T5030)	500°F
<input type="checkbox"/> Ketron® 1000 PEEK	480°F
<input type="checkbox"/> Ketron® GF30 or CA30 PEEK	480°F
<input type="checkbox"/> Techtron® PSGF PPS	450°F
<input type="checkbox"/> Techtron® 1000 PPS	425°F
<input type="checkbox"/> Semitron® ESd 410C PEI	410°F
<input type="checkbox"/> Duratron® PEI (U1000, U2300)	340°F
<input type="checkbox"/> Quadrant PPSU	300°F
<input type="checkbox"/> Quadrant PSU	300°F
<input type="checkbox"/> SYMALIT® PVDF	300°F
<input type="checkbox"/> SYMALIT® ECTFE	300°F
<input type="checkbox"/> Quadrant PC 1000	250°F
<input type="checkbox"/> Nylatron® GF30 PA66	220°F
<input type="checkbox"/> Quadrant CPVC	200°F
<input type="checkbox"/> Quadrant PPO	200°F
<input type="checkbox"/> Acetron® GP POM-C / Acetron® POM-H	180°F
<input type="checkbox"/> TIVAR® UHMW-PE	180°F
<input type="checkbox"/> PROTEUS® PP	180°F
<input type="checkbox"/> PROTEUS® HDPE	180°F
<input type="checkbox"/> Sanalite® HDPE / Sanalite® PP	180°F
<input type="checkbox"/> PROTEUS® LDPE	160°F
<input type="checkbox"/> Quadrant PVC	140°F

Max Working Stress (Continuous Load - psi)

	73°F	150°F	300°F
<input type="checkbox"/> Duratron® CU60 PBI	12,500	11,500	10,500
<input type="checkbox"/> Duratron® D7000 PI	6,750	6,200	5,670
<input type="checkbox"/> Duratron® U2300 PEI	6,200	4,600	3,000
<input type="checkbox"/> Ketron® GF30 PEEK	6,000	4,000	2,000
<input type="checkbox"/> Ketron® CA30 PEEK	6,000	4,000	2,000
<input type="checkbox"/> Duratron® PAI Grades (T4203, T4503)	5,000	4,500	3,000
<input type="checkbox"/> Techtron® PSGF PPS	5,000	4,000	750
<input type="checkbox"/> Quadrant CPVC	5,000	2,500	—
<input type="checkbox"/> Semitron® ESd 410C PEI	4,000	3,000	2,000
<input type="checkbox"/> Duratron® U1000 PEI	3,800	2,700	1,700
<input type="checkbox"/> Nylatron® GF30 PA66	3,500	2,500	—
<input type="checkbox"/> Ketron® 1000 PEEK	3,500	1,750	750
<input type="checkbox"/> Quadrant PPSU	3,000	2,200	1,500
<input type="checkbox"/> Quadrant PSU	3,000	2,200	1,000
<input type="checkbox"/> Quadrant PPO	3,000	1,200	—
<input type="checkbox"/> Quadrant PVC	2,500	1,000	—
<input type="checkbox"/> Ertalyte® PET-P	2,300	2,000	—
<input type="checkbox"/> Acetron® GP POM-C	2,200	1,800	—
<input type="checkbox"/> Acetron® POM-H	2,200	1,800	—
<input type="checkbox"/> Techtron® 1000 PPS	2,100	2,000	500
<input type="checkbox"/> Quadrant PC 1000	2,000	1,200	—
<input type="checkbox"/> Nylatron® PA66/PA6	2,000	1,200	—
<input type="checkbox"/> SYMALIT® PVDF	2,000	1,000	—
<input type="checkbox"/> Semitron® ESd 225 POM-C	1,800	1,500	—
<input type="checkbox"/> TIVAR® UHMW-PE	1,800	400	—
<input type="checkbox"/> Fluorosint® PTFE	1,500	1,000	500
<input type="checkbox"/> Semitron® ESd 500HR PTFE	1,500	1,000	500
<input type="checkbox"/> SYMALIT® ECTFE	1,000	500	—
<input type="checkbox"/> PROTEUS® HDPE	1,000	500	—
<input type="checkbox"/> Teflon® PTFE	500	250	100
<input type="checkbox"/> PROTEUS® LDPE	500	250	—
<input type="checkbox"/> PROTEUS® PP	500	250	—

What is the Primary Function of the Part?

What is the Maximum "No Load" Continuous Service Temperature? (in air)

Select only materials rated above.

To Convert from °C:
(°C x 1.8) + 32 = °F

For Bearing and Wear Applications, Determine the Pressure (or Stress) and Velocity

P=

V=

PV=

Select only materials rated above service PV

For Structural Applications, Determine the Pressure (or Stress)

Select only materials rated above service pressure

BEARING & WEAR

<input type="checkbox"/> Duratron® CU60 PBI	650°F
<input type="checkbox"/> Duratron® PI (D7000, D7015G)	500°F
<input type="checkbox"/> Fluorosint® PTFE	500°F
<input type="checkbox"/> Duratron® PAI (T4301, T4501, T4540, T7130)	500°F
<input type="checkbox"/> Ketron® 1000 PEEK	480°F
<input type="checkbox"/> Ketron® HPV PEEK	480°F
<input type="checkbox"/> Ketron® CA30 PEEK	480°F
<input type="checkbox"/> Techtron® PSBG PPS	450°F
<input type="checkbox"/> Techtron® HPV PPS	430°F
<input type="checkbox"/> Nylatron® MC®901 PA6	260°F
<input type="checkbox"/> Nylatron® GS PA66	220°F
<input type="checkbox"/> Nylatron® LIG PA6	220°F
<input type="checkbox"/> Ertalyte® PET-P / Ertalyte® TX PET-P	210°F
<input type="checkbox"/> Quadrant Nylon 101 PA66	210°F
<input type="checkbox"/> Nylatron® NSM PA6	200°F
<input type="checkbox"/> Nylatron® GSM Blue PA6	200°F
<input type="checkbox"/> Nylatron® GSM PA6	200°F
<input type="checkbox"/> Nylatron® MC®907 PA6	200°F
<input type="checkbox"/> Acetron® GP POM-C / Acetron® POM-H	180°F
<input type="checkbox"/> Acetron® AF Blend POM-H	180°F
<input type="checkbox"/> Semitron® ESd 225 POM-C	180°F
<input type="checkbox"/> TIVAR® UHMW-PE	180°F

Limiting PV (at Room Temperature) psi-fpm with 4:1 safety factor applied

<input type="checkbox"/> Duratron® CU60 PBI	37,500
<input type="checkbox"/> Ketron® CA30 PEEK	25,000
<input type="checkbox"/> Techtron® PSBG PPS	25,000
<input type="checkbox"/> Duratron® PAI (T4301, T4501)	22,500
<input type="checkbox"/> Ketron® HPV PEEK	20,000
<input type="checkbox"/> Fluorosint® HPV	20,000
<input type="checkbox"/> Nylatron® NSM PA6	15,000
<input type="checkbox"/> Duratron® T7130 PAI	14,000
<input type="checkbox"/> Techtron® HPV PPS	8,750
<input type="checkbox"/> Ketron® 1000 PEEK	8,500
<input type="checkbox"/> Acetron® AF Blend POM-H	8,300
<input type="checkbox"/> Fluorosint® 500/207 PTFE	8,000
<input type="checkbox"/> Duratron® T4540 PAI	7,500
<input type="checkbox"/> Ertalyte® TX PET-P	6,000
<input type="checkbox"/> Nylatron® LIG PA6	6,000
<input type="checkbox"/> Nylatron® GSM Blue PA6	5,500
<input type="checkbox"/> Nylatron® GS PA66 / Nylatron® GSM PA6	3,000
<input type="checkbox"/> Nylatron® MC®901 PA6/MC®907 PA6	3,000
<input type="checkbox"/> Ertalyte® PET-P	2,800
<input type="checkbox"/> Nylon 101 PA66	2,700
<input type="checkbox"/> Acetron® GP POM-C	2,700
<input type="checkbox"/> Acetron® POM-H	2,700
<input type="checkbox"/> Semitron® ESd 225 POM-C	2,000
<input type="checkbox"/> TIVAR® UHMW-PE	2,000

Quadrant Engineering Plastic Product's material selector is designed to help simplify the sometimes difficult task of choosing an appropriate thermoplastic stock shape material using application design criteria. This selector should only serve as a guide, and not a fail safe substitute for thorough design engineering.

Any material selection should be reviewed and thoroughly tested prior to actual use.

DIRECTIONS

After determining whether your application is primarily bearing and wear or structural in nature, follow that specific column to determine candidate materials. Materials that meet all of your criteria should be considered candidates for further evaluation and testing. If you have any questions about using this selector, contact Quadrant at 1-800-366-0300.

STRUCTURAL

FDA Compliant Materials

- Techtron® 1000 PPS
- Duratron® U1000 PEI (Natural & Black)
- Quadrant PPSU (Natural & Black)
- Quadrant PSU
- SYMALIT® PVDF
- Quadrant PC 1000 (Special Order Only)
- Sanalite® HDPE Cutting Board (Natural & Black)
- Sanalite® PP Cutting Board (Natural Only)
- PROTEUS® PP Homopolymer (Natural)
- PROTEUS® PP CoPolymer (Natural)
- PROTEUS® PP (White)
- PROTEUS® HDPE (Natural)
- PROTEUS® LDPE (Natural)

Chemical Environment

Strong Acids

- SYMALIT® PVDF
- Teflon® PTFE
- Fluorosint® PTFE
- TIVAR® UHMW-PE
- SYMALIT® ECTFE
- PROTEUS® HDPE/LDPE
- PROTEUS® PP
- Ketron® 1000 PEEK
- Techtron® 1000 PPS
- Techtron® PSGF PPS
- Quadrant PPSU
- Duratron® U1000 PEI
- Quadrant PC 1000
- Quadrant PSU

BEST

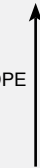

Strong Alkalies

- TIVAR® UHMW-PE
- Ketron® 1000 PEEK
- Techtron® PPS Products
- Quadrant PPSU
- Quadrant PPO
- Quadrant PSU
- Teflon® PTFE
- Fluorosint® PTFE

Steam

- SYMALIT® PVDF
- Teflon® PTFE
- Fluorosint® 500 PTFE
- SYMALIT® ECTFE
- Quadrant PVC
- Quadrant CPVC
- Ketron® 1000 PEEK
- Techtron® 1000 PPS
- Quadrant PPSU
- Duratron® U1000 PEI
- Quadrant PSU

BEST



Chlorine (Aqueous)

- TIVAR® 1000 PE
- Ketron® 1000 PEEK
- Techtron® PPS Products
- Ertalyte® PET-P
- Quadrant PPSU
- Duratron® U1000 PEI
- Teflon® PTFE
- Fluorosint® 500 PTFE

Size Capability

	ROD (DIAMETERS)	PLATE (THICKNESS)
<input type="checkbox"/> Duratron® CU60 PBI ^Δ	.375" - 3.75"	.500" - 1.50"
<input type="checkbox"/> Fluorosint® PTFE	.50" - 8.75"	.250" - 3.00"
<input type="checkbox"/> Duratron® T4203 PAI	.062" - 2.00"	.250" - 1.25"
<input type="checkbox"/> Duratron® T4503 PAI ^Δ	2.25" - 10.00"	—
<input type="checkbox"/> Duratron® T5030 PAI	.375" - 1.50"	.187" - .375"
<input type="checkbox"/> Semitron® Esd 500HR PAI	—	.250" - 2.00"
<input type="checkbox"/> Ketron® 1000 PEEK	.125" - 6.00"	.250" - 4.00"
<input type="checkbox"/> Ketron® CA30 PEEK	.236" - 3.15"	.197" - 2.36"
<input type="checkbox"/> Ketron® CM CA30 PEEK ^Δ	1.00" - 3.55"	—
<input type="checkbox"/> Ketron® GF30 PEEK	.236" - 4.00"	.197" - 2.36"
<input type="checkbox"/> Ketron® CM GF30 PEEK ^Δ	1.00" - 1.625"	—
<input type="checkbox"/> Techtron® PSGF PPS ^Δ	1.00" - 4.00"	.375" - 2.00"
<input type="checkbox"/> Techtron® 1000 PPS	.250" - 5.00"	.250" - 2.00"
<input type="checkbox"/> Semitron® Esd 410C PEI	.375" - 3.00"	.375" - 2.00"
<input type="checkbox"/> Duratron® U1000 PEI	.125" - 8.00"	.250" - 4.00"
<input type="checkbox"/> Duratron® U2300 PEI	.500" - 6.00"	.375" - 3.00"
<input type="checkbox"/> Quadrant PPSU	.250" - 8.00"	.250" - 3.00"
<input type="checkbox"/> Quadrant PSU	.250" - 6.00"	.250" - 3.00"
<input type="checkbox"/> SYMALIT® PVDF	—	.125" - 1.00"
<input type="checkbox"/> SYMALIT® ECTFE	—	.125" - 1.00"
<input type="checkbox"/> Quadrant PC 1000	.062" - 6.00"	.250" - 3.00"
<input type="checkbox"/> Nylatron® GF30 PA66	.394" - 7.92"	.394" - 3.94"
<input type="checkbox"/> Quadrant CPVC	—	.250" - 2.00"
<input type="checkbox"/> Quadrant PPO	.250" - 6.00"	.250" - 3.00"
<input type="checkbox"/> PROTEUS® HDPE / PP	—	.062" - 3.00"
<input type="checkbox"/> Sanalite HDPE / PP	—	.250" - 1.00"
<input type="checkbox"/> PROTEUS® LDPE	—	.062" - 1.00"
<input type="checkbox"/> Quadrant PVC	—	.062" - 2.00"

**Is FDA/USDA/
NSF/3A
Dairy
Compliance
Required?**

Yes ___ No ___

See the Regulatory Compliance Chart on page 36 of this manual for complete details on all materials.

**What
Chemicals
will be
Encountered
During
Service or
Cleaning?**

- ___ Strong Acids (pH 1-3)
- ___ Strong Alkalies (pH 9-14)
- ___ Hot Water / Steam
- ___ Chlorine (aqueous)

For resistance to other chemicals, see pages 32 through 35 of this manual, or contact Quadrant's Technical Service.

**What Size
Stock Shape
is Required
for
Machining?**

Rod ___
Plate ___

(Custom sizes including disc and tubular bar are also available in cast and compression molded materials.)

^Δ Products are compression molded and typically available in rod, plate, tubular bar and discs. Rod and tube lengths range from 3" to 12". Plate sizes are 12" x 12", 13-1/4" x 14-1/4", and 14" x 28".

^{ΔΔ} FDA compliant by special order only.

BEARING & WEAR

FDA Compliant Materials

- Fluorosint® 207 PTFE
- Fluorosint® HPV PTFE
- Ketron® 1000 PEEK (Natural)
- Techtron® HPV PPS
- TIVAR® H.O.T. UHMW-PE
- Nylatron® MC® 907 PA6
- Nylatron® LFG PA6
- Ertalyte® TX PET-P
- Ertalyte® PET-P (Natural & Black)
- Quadrant Nylon 101 PA66
- Acetron® GP POM-C (Natural & Black)
- Acetron® POM-H (Natural)
- TIVAR® 1000 UHMW-PE (Natural)
- TIVAR® Oil-Filled UHMW-PE (Brown & Grey)
- TIVAR® CleanStat UHMW-PE (Black)
- TIVAR® H.O.T. UHMW-PE

Chemical Environment

Strong Acids

- Fluorosint® PTFE
- TIVAR® UHMW-PE
- Ketron® 1000 PEEK
- Ketron® CA30 PEEK
- Ketron® HPV PEEK
- Techtron® HPV PPS
- Techtron® PSBG PPS

BEST

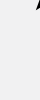

Strong Alkalies

- TIVAR® UHMW-PE
- Ketron® 1000 PEEK
- Ketron® CA30 PEEK
- Ketron® HPV PEEK
- Techtron® HPV PPS
- Techtron® PSBG PPS
- Fluorosint® PTFE

Steam

- Fluorosint® PTFE
- Ketron® 1000 PEEK
- Ketron® CA30 PEEK
- Techtron® HPV PPS
- Techtron® PSBG PPS
- Ketron® HPV PEEK
- Acetron® GP POM-C

BEST



Chlorine (Aqueous)

- Fluorosint® PTFE
- TIVAR® UHMW-PE
- Ketron® 1000 PEEK
- Ketron® CA30 PEEK
- Ketron® HPV PEEK
- Ertalyte® PET-P
- Ertalyte® TX PET-P

Size Capability

	ROD (DIAMETERS)	PLATE (THICKNESS)
<input type="checkbox"/> Duratron® CU60 PBI ^Δ	.375" - 3.75"	.500" - 1.50"
<input type="checkbox"/> Fluorosint® PTFE	.50" - 8.75"	.250" - 3.00"
<input type="checkbox"/> Duratron® T4301 PAI	.25" - 3.00"	.250" - 1.00"
<input type="checkbox"/> Duratron® T4501 PAI ^Δ	2.25" - 10.00"	.375" - 1.50"
<input type="checkbox"/> Duratron® T7130 PAI	.375" - 1.50"	.187" - .375"
<input type="checkbox"/> Ketron® PEEK	.125" - 6.00"	.250" - 4.00"
<input type="checkbox"/> Ketron® HPV PEEK	.236" - 3.94"	.197" - 2.36"
<input type="checkbox"/> Ketron® CA30 PEEK	1.00" - 3.75"	—
<input type="checkbox"/> Techtron® PSBG PPS ^Δ	1.00" - 5.00"	.375" - 1.75"
<input type="checkbox"/> Techtron® HPV PPS	.236" - 3.94"	.198" - 3.15"
<input type="checkbox"/> Nylatron® MC® 901 PA6	2.00" - 38.00"	.187" - 6.00"
<input type="checkbox"/> Nylatron® GS PA66	.062" - 2.00"	.031" - 2.00"
<input type="checkbox"/> Nylatron® LIG PA6	2.00" - 38.00"	.187" - 6.00"
<input type="checkbox"/> Ertalyte® PET-P	.375" - 7.08"	.078" - 4.00"
<input type="checkbox"/> Ertalyte® TX PET-P	.394" - 7.88"	.315" - 3.94"
<input type="checkbox"/> Quadrant Nylon 101 PA66	.062" - 6.00"	.031" - 3.00"
<input type="checkbox"/> Nylatron® NSM PA6	2.00" - 38.00"	.187" - 4.00"
<input type="checkbox"/> Nylatron® GSM Blue PA6	2.00" - 38.00"	.187" - 6.00"
<input type="checkbox"/> Nylatron® GSM PA6	2.00" - 38.00"	.187" - 6.00"
<input type="checkbox"/> Nylatron® MC® 907 PA6	2.00" - 38.00"	.187" - 6.00"
<input type="checkbox"/> Acetron® GP POM-C	.062" - 12.00"	.031" - 4.50"
<input type="checkbox"/> Acetron® POM-H	.25" - 8.00"	.250" - 4.00"
<input type="checkbox"/> Acetron® AF Blend POM-H	.187" - 6.00"	.250" - 3.00"
<input type="checkbox"/> Semitron® Esd 225 POM-C	.187" - 6.00"	.250" - 4.00"
<input type="checkbox"/> TIVAR® UHMW-PE	.25" - 10.00"	.062" - 6.00"

Note: CF = Carbon fiber reinforced
GF = Glass fiber reinforced
BG = Bearing grade
ESD = Electrostatic dissipative
CM = Compression molded

[MATERIAL SELECTION

STRUCTURAL

Stability	CLTE	H ₂ O Absorp. (Saturation)	BEST
Duratron® CU60 PBI	1.3 x 10 ⁻⁵	5.00*	↑
Duratron® U2300 PEI	1.1 x 10 ⁻⁵	0.90	
Duratron® PAI (T4203, T4503)	1.3 x 10 ⁻⁵	1.50	
Ketron® GF30 PEEK	1.4 x 10 ⁻⁵	0.50	
Semitron® ESd 410C PEI	1.8 x 10 ⁻⁵	1.25	
Fluorosint® 500 PTFE	2.1 x 10 ⁻⁵	0.30	
Techtron® PSGF PPS	2.5 x 10 ⁻⁵	0.03	
Techtron® 1000 PPS	2.8 x 10 ⁻⁵	0.03	
Nylatron® GF30 PA66	3.1 x 10 ⁻⁵	7.00	
Quadrant PPSU	3.1 x 10 ⁻⁵	1.10	
Duratron® U1000 PEI	3.1 x 10 ⁻⁵	1.25	
Quadrant PSU	3.1 x 10 ⁻⁵	0.60	
Quadrant PVC	3.2 x 10 ⁻⁵	0.01	
Quadrant CPVC	3.4 x 10 ⁻⁵	0.01	
Quadrant PPO	3.6 x 10 ⁻⁵	0.01	
Quadrant PC 1000	3.9 x 10 ⁻⁵	0.40	
PROTEUS® PP	4.3 x 10 ⁻⁵	0.01	
Semitron® ESd 500HR PTFE	5.7 x 10 ⁻⁵	2.00	
PROTEUS® LDPE	6.0 x 10 ⁻⁵	0.01	
SYMALIT® PVDF	6.6 x 10 ⁻⁵	0.05	
SYMALIT® ECTFE	6.6 x 10 ⁻⁵	0.01	
PROTEUS® HDPE	6.7 x 10 ⁻⁵	0.01	

Is Dimensional Stability Over a Temperature Range Critical?

Select a material with the lowest coefficient of linear thermal expansion (in./in./°F) or lowest water absorption.

*Applications requiring Duratron® CU60 PBI are typically dry due to high temperatures.

Is Toughness or Impact Resistance Critical in Use?

Select the most impact resistant material if toughness is critical.

Toughness or Impact Resistance

Tough Materials

Quadrant PPSU
Quadrant PC 1000
SYMALIT® PVDF
SYMALIT® ECTFE
PROTEUS® LDPE
PROTEUS® PP - CoPolymer
Quadrant PPO

Average Toughness

Duratron® PAI (T4203, T4503, T5030, T5530)
Duratron® U1000 PEI
Techtron® 1000 PPS
Quadrant PSU
PROTEUS® HDPE
PROTEUS® PP - Homopolymer
Quadrant CPVC

Notch Sensitive Materials

Nylatron® GF30 PA66
Quadrant PVC
Semitron® ESd 410C PEI
Duratron® U2300 PEI
Ketron® GF30 PEEK
Ketron® CF30 PEEK
Techtron® PSGF PPS
Duratron® CU60 PBI

BEARING AND WEAR

Stability	CLTE	H ₂ O Absorp. (Saturation)
Duratron® CU60 PBI	1.3 x 10 ⁻⁵	5.00*
Duratron® PAI (T4301, T4501)	1.4 x 10 ⁻⁵	1.50
Techtron® PSBG PPS	1.7 x 10 ⁻⁵	0.03
Ketron® CF30 PEEK	1.7 x 10 ⁻⁵	0.50
Ketron® HPV PEEK	1.7 x 10 ⁻⁵	0.30
Fluorosint® 500 PTFE	2.1 x 10 ⁻⁵	0.30
Ketron® 1000 PEEK	2.6 x 10 ⁻⁵	0.50
Techtron® HPV PPS	3.3 x 10 ⁻⁵	0.10
Ertalyte® PET-P	3.3 x 10 ⁻⁵	0.90
Nylatron® MC® 901/907 PA6	3.5 x 10 ⁻⁵	7.00
Nylatron® GSM PA6	3.5 x 10 ⁻⁵	7.00
Nylatron® GS PA66	4.0 x 10 ⁻⁵	7.00
Ertalyte® TX PET-P	4.5 x 10 ⁻⁵	0.50
Acetron® POM-H	4.7 x 10 ⁻⁵	0.90
Acetron® AF Blend POM-H	5.0 x 10 ⁻⁵	1.00
Nylatron® NSM PA6	5.0 x 10 ⁻⁵	7.00
Acetron® GP POM-C	5.4 x 10 ⁻⁵	0.90
Quadrant Nylon 101 PA66	5.5 x 10 ⁻⁵	7.00
Fluorosint® 207 PTFE	5.7 x 10 ⁻⁵	2.00
Nylatron® LIG PA6	5.8 x 10 ⁻⁵	6.00
Nylatron® GSM Blue PA6	5.9 x 10 ⁻⁵	7.00
TIVAR® UHMW-PE	9.2 x 10 ⁻⁵	0.01
Semitron® ESd 225 POM-C	9.3 x 10 ⁻⁵	8.00

Toughness or Impact Resistance

Tough Materials

Techtron® HPV PPS
Nylatron® MC901 PA6
Nylatron® MC907 PA6
Nylatron® GSM PA6
Nylatron® GSM Blue PA6
TIVAR® 1000 UHMW-PE

Average Toughness

Quadrant Nylon 101 PA66
Nylatron® NSM PA6
Acetron® GP POM-C
Acetron® POM-H
Acetron® AF Blend POM-H
Semitron® ESd225 POM-C
Ertalyte® TX PET-P
Fluorosint® 500 PTFE
Fluorosint® 207 PTFE
Ketron® HPV PEEK
Ketron® 1000 PEEK
Duratron® PAI (T4301, T4501)

Notch Sensitive Materials

Nylatron® GS PA66
Ertalyte® PET-P
Techtron® PSBG PPS
Duratron® CU60 PBI

STRUCTURAL

Relative Cost Factor

Semitron® ESd 520HR PTFE	36.4
Ketron® GF30 PEEK	34.0
Duratron® PAI (T4203, T4503)	28.1
Semitron® ESd 410C PEI	17.3
Techtron® 1000 PPS	15.9
Quadrant PPSU	9.0
Techtron® PSGF PPS	8.1
Duratron® U2300 PEI	7.0
Nylatron® GF30 PA66	4.5
Quadrant PSU	4.0
Duratron® U1000 PEI	3.9
Teflon® PTFE	3.0
Quadrant PC 1000	1.7
SYMALIT® PVDF	2.8
SYMALIT® ECTFE	2.8
Quadrant CPVC	1.2
Quadrant PPO	1.5
PROTEUS® PP	0.3
PROTEUS® HDPE	0.2
Sanalite® HDPE / PP	0.3
PROTEUS® LDPE	0.3
Quadrant PVC	1.1

**What
Materials
Meet
Performance
Requirements
and Offer the
Best Value?**

All costs are estimates relative to Quadrant Nylon 101 PA66. Please note that size availability and near net shapes can reduce material cost.

BEARING AND WEAR

Relative Cost Factor

Duratron® CU60 PBI	76.4
Ketron® CA30 PEEK	55.0
Ketron® HPV PEEK	30.3
Duratron® PAI (T4301, T4501)	28.1
Techtron® HPV PPS	22.0
Ketron® 1000 PEEK	19.8
Techtron® PSBG PPS	17.8
Fluorosint® PTFE	12.1
Semitron® ESd 225 POM-C	3.3
Acetron® AF Blend POM-H	3.5
Ertalyte® TX PET-P	1.8
Ertalyte® PET-P	1.6
Nylatron® NSM PA6	1.4
Acetron® GP POM-C	1.2
Acetron® POM-H	1.2
Nylatron® GSM Blue PA6	1.2
Nylatron® GS PA66	1.0
Nylatron® GSM PA6	1.0
Nylatron® LIG PA6	1.2
Nylatron® MC907 PA6	1.0
Nylatron® MC901 PA6	1.0
Quadrant Nylon 101 PA66	1.0
TIVAR® UHMW-PE	0.5

Note: CF = Carbon fiber reinforced
GF = Glass fiber reinforced
BG = Bearing grade
ESD = Electrostatic dissipative
CM = Compression molded

Material Selection:

1. _____
(1st choice)

2. _____
(Alternate)

3. _____
(Alternate)

For other special environmental conditions (i.e. Radiation, Static Dissipation, etc.), please call Quadrant's Technical Service Group at 1-800-366-0300

[BEARING DESIGN

Engineering thermoplastics are commonly used as bearings on newly designed and existing machinery replacing:

- rolling element bearings
- metallic plane bearings
- slide pads
- soft metals such as bronze and lead alloys

With plastics' inherently low friction properties, designers often eliminate the need for external lubrication while reducing potential damage to mating surfaces. Selection of an appropriate plastic bearing material requires consideration of an application's unit pressure, calculated linear velocity, ambient temperature and operation cycle time. Other special application requirements such as chemical resistance, dimensional stability and impact resistance must also be considered before final material selection.

After choosing an appropriate material, design of the bearing (especially running clearance for any journal bearing) is required.

Measuring Operating PV

Determining Surface Velocity

For sleeve bearings, the formula $V = 0.262 \times \text{rpm} \times D$ is used to determine the surface velocity in fpm, from the shaft diameter, "D" (in.) and the shaft revolutions per minute, or rpm. For linear motion, the surface velocity is the speed at which the sliding surface is moving across the mating surface.

Determining Unit Pressure

The unit pressure "P" is quickly calculated for flat wear surfaces and sleeve bearings. For flat bearing surfaces, P is simply the total load (lbs.) divided by the total contact area expressed in square inches (in.²). For sleeve bearings, P is calculated by dividing the total load on the bearing by the projected area of the bearing surface. The projected area of sleeve bearings is calculated by multiplying the bearing I.D. (inches) by the bearing length (inches), see Figure 14.

DESIGN TIP

The maximum unit pressure must always be less than the compressive strength of a selected material. A good design practice is to use the "working stress" listed on page 12 of this manual as the maximum unit pressure for a plastic bearing.

Fig. 14

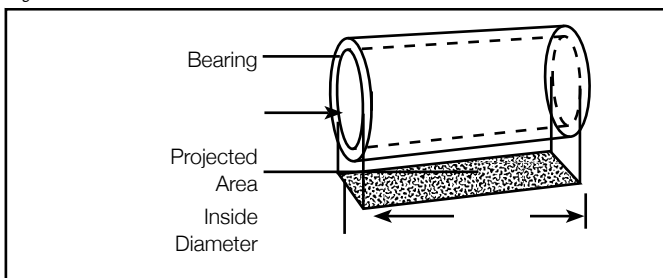

A thermoplastic material must have enough structural and thermal capability to sustain operation at the given application PV. This capability is measured as a material's Limiting PV (LPV). This term is commonly reported as a single value although it may vary for extremes in velocity and load.

Table 3 : Basic Limiting PV (LPV) for Quadrant's Bearing Material

Material	PVL Unlubricated
Duratron® D7015G PI	40,000
Duratron® PBI	37,500
Ketron® CM HPV PEEK	35,000
Techtron® PSBG PPS	25,000
Duratron® T4301/T4501	22,500 ^Δ
Fluorosint® HPV PTFE	20,000
Ketron® HPV PEEK	20,000
Nylatron® NSM PA6	15,000 ^{ΔΔ}
Techtron® HPV PPS	8,750
Ketron® 1000 PEEK	8,500
Acetron® AF Blend POM-H	8,300
Fluorosint® 207 PTFE/500 PTFE	8,000
Ertalyte® TX PET-P	6,000
Nylatron® GSM Blue PA6	5,500
MC® Nylons/Nylatron® GS/GSM	3,000
Ertalyte® PET-P	2,800
Quadrant Nylon 101 PA66	2,700
Acetron® POM-C/POM-H	2,700

Operating without lubrication and with ambient temperature of 75°F. Units of LPV are (PSI)(FPM). (4:1 Safety Factor applied)

^Δ Value represents the LPV for a machined part without post curing after machining. Post curing parts machined from extruded or injection molded Duratron® PAI significantly increases the LPV to as high as 45,000.

^{ΔΔ} At surface speeds below 20 ft./min. the LPV (Basic Limiting PV) may be doubled.

Applying the PV Factor

Table 3 presents LPV values for various Quadrant plastic bearing materials. LPV is the maximum PV that a given material can withstand at 75°F., running continuously without lubrication. The basic LPV taken from this table must be modified to compensate for ambient temperatures other than 75°F., and for the cycle time, if continuous operation is not required.

Modification of LPV is accomplished by multiplying by the correction factors ("H" and "C") obtained from Figures 15 and 16. When ambient temperature is approximately 75°F., H=1 and when bearings are run continuously, C=1. Therefore LPV as listed in Table 3 can be used as PVa.

DESIGN TIP

Continuous lubrication including oil, grease and water greatly increase the service limits of thermoplastic bearings. Lubrication is usually suggested for velocities greater than 400 fpm.

Ambient Temperature Correction (H)

When ambient temperature (surrounding temperature, not heat generated in the bearing from operation) is higher or lower than 75°F., PV capabilities change.

Since ambient temperatures above or below 75°F affect the allowable temperature rise and load capability of thermoplastic bearings, use Figure 15 to compensate PV for variations in ambient temperature.

$$PV_a = PV \times H$$

Fig. 15

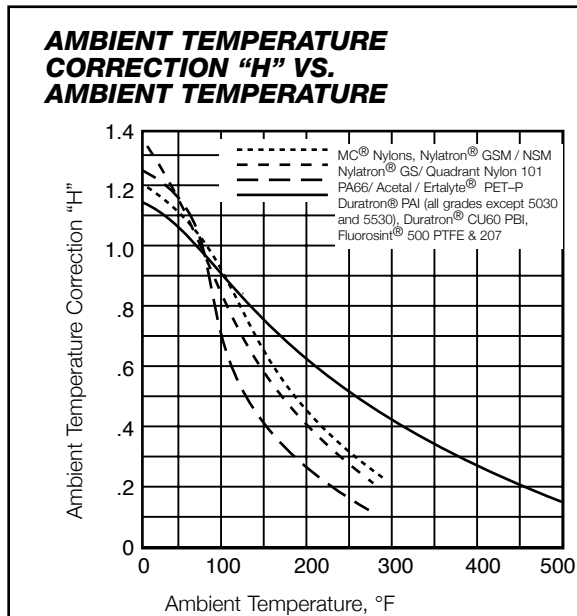

Cycle Time Correction (C)

The rates of heat generation and heat dissipation greatly determine the performance of plastic bearings. If operation is intermittent rather than continuous, the rate of heat generation is reduced although the rate of heat dissipation remains constant.

Instructions for use of Figure 16

Locate operating period or "on" period on horizontal scale. Read upwards to intersect with the appropriate curve. If the off period is the same as the on period, use the (1X) curve. If the off period is two times the on period, use the (2X) curve. Interpolate conservatively. For example, if off period is three and one-half times the on period, use the (3X) curve.

$$PV_a = PV \times C$$

Fig. 16

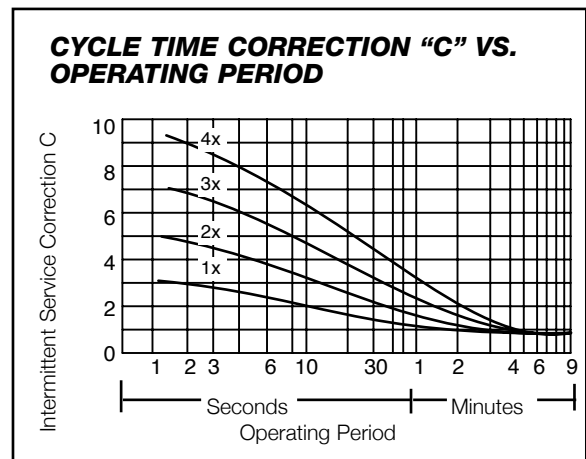

TIVAR® UHMW-PE Bushing/Bearings Design Specifications

Press Fitting TIVAR® UHMW-PE Bearings:

- Add .8 to 1.0% to the nominal OD on bearing:

$$(OD_b - ID_h) / ID_h \times 100 = .8\% \text{ to } 1.0\%$$

$$OD_b = \text{Bearing OD}$$

$$ID_h = \text{Mating Housing ID}$$

- Bearing length to diameter (Fig. 1B) should be equal to or less than 1.5: $L/OD_b \leq 1.5$
- For each .004" or .10mm added to the nominal bushing O.D. for press fitting into a housing, the bushing I.D. will close in .001" or .02mm.

Shaft Diameters/TIVAR® UHMW-PE Bearings:

- To produce a running fit, increase the nominal bearing I.D. by .001" or .03mm for shaft diameters less than 1" or 25mm in size.
- To produce a running fit on shafts 1" or 25mm and larger, increase the nominal bearing I.D. by .003" or .07mm for each 1" or 25mm in size.
- Recommended bearing wall thickness is one tenth of shaft diameter when designing a TIVAR® bearing.
- Increase the wall thickness for shock load conditions and decrease the wall thickness for applications near P.V. limits.
- It is recommended that the length of a TIVAR® UHMW-PE bearing be equal to the shaft diameter unless under a high load, where more surface area is required to resist creep.

Fig. 1B

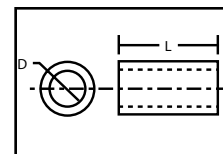

BEARING DESIGN

In many bearing applications, the nominal wall thickness is dictated by the geometry of existing equipment. The plastic bearing is designed from the dimensions of the shaft and the housing.

DESIGN TIP

TIVAR® UHMW-PE materials have a lower mechanical strength than other traditional thermoplastic bearings. As a result, please review TIVAR® Bushing/ Bearing Design Specifications on Page 17.

Fig. 17 - SUGGESTED NOMINAL WALL THICKNESS

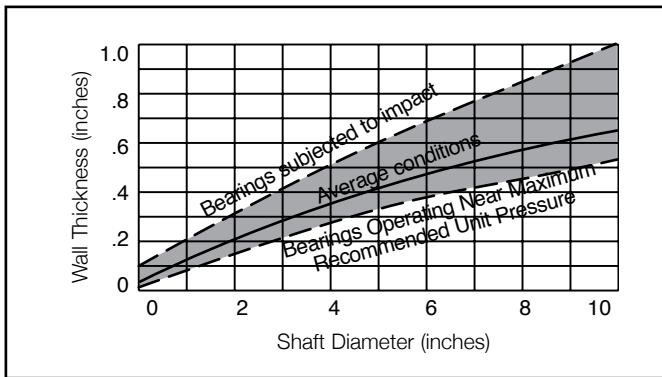

When new equipment is being designed, the engineer is at greater liberty to establish nominal wall thickness. Figure 17 suggests a range of nominal wall thicknesses for different shaft diameters. Maximum walls are recommended for bearings subjected to severe impact conditions, minimum walls for bearings operating near the material's maximum recommended PV.

Bearing Length / Diameter Ratio

Bearing length to shaft diameter ratio has a noticeable effect on bearing friction. For a ratio of 1:1 (bearing length equal to the shaft diameter), friction is generally lowest. As the bearing length is increased to two or three times the shaft diameter, there is increased friction and an increased probability of local heating due to out-of-roundness and shaft vibration. On the other hand, very short bearings are often difficult to retain within the bearing housing.

Clearance

Clearance has been the least understood and most frequently encountered problem in the design of plastic bearings. Most plastic bearing failures are caused by insufficient clearance.

Table 4 : Wall factor for plastic bearing materials at various ambient temperatures - for calculation of (a₂) (inches)

	75°	100°	125°	150°	175°	200°	225°	250°	275°	300°	350°	400°	450°	500°
Quadrant Nylon 101 PA66/Acetron® POM	.018	.021	.023	.026	.028	.031	.033	.036	.038					
Nylatron® PA6 grades	.015	.016	.018	.019	.021	.023	.024	.026	.026					
Nylatron® GS, Ertalyte® PET-P	.013	.015	.016	.018	.020	.022	.023	.025	.027					
Fluorosint® PTFE	.007	.007	.008	.008	.009	.009	.010	.010	.011	.011	.012	.013	.014	.015
Ketron® HPV PEEK, Techtron® HPV PPS	.007	.007	.008	.008	.009	.009	.010	.010	.011	.011	.012	.013	.014	.015
Bearing grade Duratron® PAI	.007	.007	.008	.008	.009	.009	.010	.010	.011	.011	.012	.013	.014	.015
Duratron® CU60 PBI	.007	.007	.008	.008	.009	.009	.010	.010	.011	.011	.012	.013	.014	.015

Note: For temperatures other than given use the next highest temperature that appears in the table.

Plastic bearing clearances are much greater than those recommended for metal bearings. Metal bearings installed with excessive clearance often result in shaft vibrations and scoring (brinnelling) of the bearing and shaft. Plastics, on the other hand, are far more resilient, resist scoring and dampen shaft vibration.

Total running clearance is obtained by adding three allowances. The total running clearance is then added to the nominal bearing I.D. (shaft diameter) to obtain the actual or design I.D. of the bearing. Total running clearance = a₁ + a₂ + a₃, where:

a₁ = Basic shaft allowance (obtain value from Figure 18).

a₂ = Wall thickness allowance (a function of the bearing material, bearing wall thickness, and the ambient operating temperature) (obtain wall factor from Table 4 and multiply by the nominal wall thickness to obtain a₂).

a₃ = Used only when the bearing is to be press fit. Note that a₃ is the same as the recommended press fit interference (obtain from Figure 19).

Fig. 18 - SHAFT ALLOWANCE (a₁) VERSUS SHAFT DIAMETER

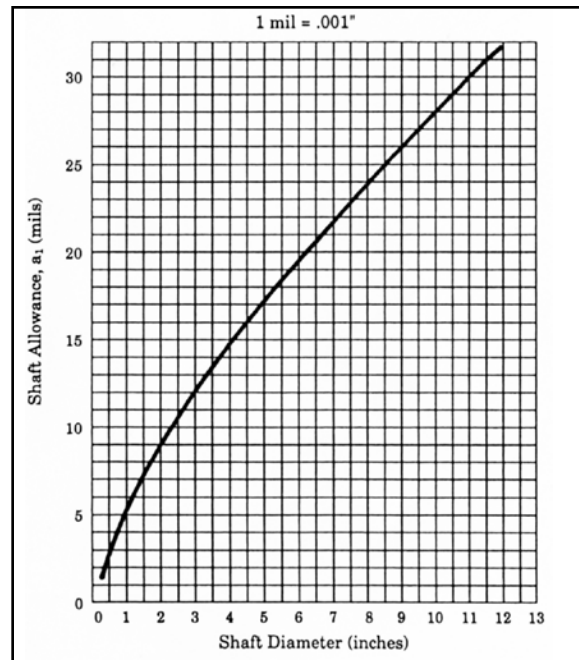
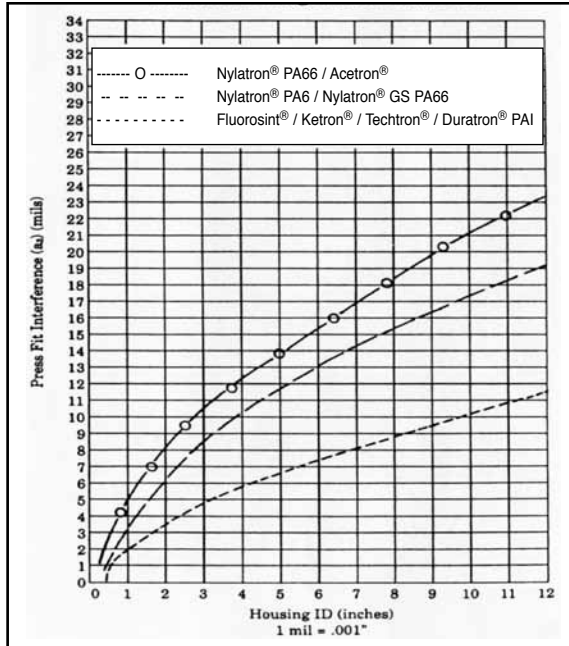

Fig. 19 - **RECOMMENDED PRESS FIT INTERFERENCE (A₁) VERSUS HOUSING INSIDE DIAMETER**



The basic shaft allowance (a₁) is the same for all plastic bearing materials and depends only on the diameter of the shaft to be supported. Figure 18 was developed from application data on plastic bearings.

Wall thickness allowance (a₂) is derived from the coefficients of thermal expansion for the plastic bearing materials. Each plastic reacts to changing temperatures at a characteristic rate. The thicker the bearing wall, the more material there is available to expand with higher temperature. Hence, Table 4 demonstrates that with higher ambient temperatures and/or thicker bearing walls the greater the required running clearance.

Press Fit into Metallic Housing

When plastic bearings are press fit into metallic housings or retainers, a recommended interference (Figure 19) should be used to ensure the bushing is adequately secured to resist rotating with the shaft. During press fit, the plastic bearing conforms to the housing I.D., therefore, the I.D. of the bearing closes-in. The I.D. close-in will approximately equal the press fit interference. Close-in is compensated with an additional I.D. clearance equal to the interference (a₂).

Shafts and Mating Parts

Shafts and mating parts perform best if made from hardened and ground steel. Unhardened steel surfaces will wear quickly in many applications, particularly if unlubricated. Commercial shafting normally is supplied with a surface hardness of Rockwell C-55, although shafting with Rockwell hardnesses as low as C-35 will perform satisfactorily. Shafts and mating parts of stainless steel should be specified in a hardenable grade. In general, harder stainless grades such as 316 are suggested over 303/304 grades.

Mating metal parts should have a smooth surface obtained by grinding or hard plating. Commercial shafting normally is finished to 16 RMS although a 32 RMS is usually acceptable. The finish of the plastic bearing is not critical and can be as coarse as 125 RMS.

DESIGN TIP

•If your bearing is to be water lubricated and made from a Quadrant Engineering Plastic Products' nylon, an additional clearance must be added for moisture expansion of the nylon. Use clearances below regardless of bearing diameters. Note that as wall thickness increases, moisture clearance increases in progressively smaller amounts. This is due to the increasing resistance of the thicker sections to moisture penetration.

Moisture expansion clearance (only if water-lubricated nylon bearing)
If bearing wall thickness in inches is:

1/8"	clearance in inches is	0.012"
3/16"	clearance in inches is	0.017"
1/4"	clearance in inches is	0.021"
3/8"	clearance in inches is	0.026"
1/2"	clearance in inches is	0.030"
3/4"	clearance in inches is	0.032"
1" +	clearance in inches is	0.033"

•Non-hygroscopic materials such as Ertalylte® PET-P and Acetron® GP POM-C may offer improved wear resistance in wet environments.

•Internally lubricated materials such as Nylatron® NSM PA6, Nylatron® GSM Blue PA6 nylon and Ertalylte® TX provide the lowest cost in use when application PV is less than Limiting PV.

Bearing and Wear Properties Comparison

Material	Continuous Service Temp.	Limiting PV	"k" Factor	Coefficient of Friction (Dynamic)	Compressive Strength	Cost Factor
TIVAR® 1000 UHMW-PE	180	2,000	111	0.12	3,000	0.5
Acetron® GP POM-C	180	2,700	200	0.25	15,000	1.2
Acetron® POM-H	180	2,700	200	0.25	16,000	1.2
Acetron® AF Blend POM-H	180	8,300	60	0.19	16,000	3.5
Semitron® ESd 225 POM-C	180	2,000	30	0.29	8,000	3.3
Nylatron® 703XL PA6	200	17,000	26	0.14	10,000	1.5
Nylatron® GSM Blue PA6	200	5,500	65	0.18	13,000	1.2
Quadrant Nylon 101 PA66	200	2,700	80	0.25	12,500	1.0
Nylatron® MC 907 PA6	200	3,000	100	0.20	15,000	1.0
Nylatron® GSM PA6	200	3,000	90	0.20	14,000	1.2
Nylatron® GS PA66	200	3,000	90	0.20	16,000	1.2
Nylatron® NSM PA6	200	15,000	12	0.18	14,000	1.4
Ertalylte® PET-P	210	2,800	60	0.20	15,000	1.6
Ertalylte® TX PET-P	210	6,000	35	0.19	15,250	1.8
Nylatron® LIG/LFG PA6	220	6,000	90	0.14	13,500	1.2
Nylatron® MC® 901 PA6	260	3,000	100	0.20	15,000	1.0
Techtron® HPV PPS	430	8,750	62	0.20	15,500	22.0
Techtron® PSBG PPS	450	25,000	800	0.20	15,000	17.8
Ketron® 1000 PEEK	480	8,500	375	0.40	20,000	19.8
Ketron® CA30 PEEK	482	25,000	150	0.20	29,000	55.0
Ketron® HPV PEEK	482	20,000	100	0.21	20,000	30.3
Duratron® T4301 PAI	500	22,500	10	0.20	22,000	28.1
Duratron® T4501 PAI	500	22,500	45	0.20	16,000	28.1
Fluorosint® 500 PTFE	500	8,000	600	0.15	4,000	12.1
Fluorosint® 207 PTFE	500	8,000	30	0.10	3,800	12.1
Fluorosint® HPV PTFE	500	20,000	38	0.15	3,000	12.1
Duratron® D7015G PI	500	40,000	10	0.25	25,000	63.5
Duratron® CU60 PBI	600	37,500	60	0.24	50,000	76.4

BEARING DESIGN

This worksheet applies to sleeve bearings only. If the bearing has another configuration, sketch and note all dimensions and fax to Quadrant Technical Service at (610) 320-6866.

INFORMATION REQUIRED

Housing bore _____ in.
 Shaft diameter _____ in.
 Length _____ in.
 Shaft rpm _____
 Bearing load _____ lbs.
 How many bearings/shaft _____
 Ambient temperature _____ °F
 Cycle - Continuous _____
 - Intermittent _____
 - Time on _____ Time off _____
 Is bearing lubricated? _____
 How? _____

Total Running Clearance

$a_1 + a_2 + a_3$
 a_1 = Figure 18 (page 18)
 a_2 = Table 4 (page 18) for ambient temp. to 90°F
 = Bearing wall $\left(\frac{OD - ID}{2}\right)$ x Temp. factor for material
 a_3 = Figure 19 (page 19) – used if bearing is press fit

Dimension Bearing

Housing dia. _____ + a_3 _____
 = _____ OD of bearing _____
 Shaft dia. _____ + a_1 _____ + a_2 _____ + a_3 _____
 = _____ ID of bearing _____
 If a nylon bearing is to be used in a water lubricated environment, add factor given in Design Tips on page 19 to the ID of the bearing to allow for moisture absorption –
 _____ + Moisture absorption clearance _____
 = _____ ID of bearing _____
 Length of housing _____

PV Determination

Projected area

Bearing ID _____ x Length _____
 = _____ sq. in.

Pressure

Bearing load _____ ÷ Projected area _____
 = _____ psi

Velocity

0.262 x _____ rpm x Shaft diameter _____
 = _____ fpm

(Note: do not exceed 400 fpm for velocity)

PV - imposed PV on bearing

_____ psi x _____ fpm _____
 = _____ PV

See Table 3 on page 16 for Limiting PV

Lubricated _____
 Unlubricated _____

Material Selected _____

Corrections for Limiting PV - See page 17 (Figures 15 and 16)

Figure 15 – Temperature Correction H = _____

Figure 16 – Cycle Time Correction C = _____

PV Correction

Limiting PV _____ x Temp. (H) _____ x Cycle (C) _____
 = _____ PV Limit

If the imposed PV is less than the PV limit for the material selected, the bearing will work.

Dimensions and Tolerances

OD = _____ ±0.004 or ± 0.001 in./in. of dia.

OD = _____ + _____

_____ + 0.008
 ID = _____ - 0.000 or + 0.002/-0.000 in./in. of dia.

ID = _____ + _____
 - 0.000"

Length = _____ ±0.010 or ± 0.001 in./in. of length

Length = _____ + _____

The greater of the tolerances will apply.

[ROLLER/WHEEL DESIGN

Rigid plastic rollers and wheels are commonly specified instead of metal. The non-abrasive and vibration dampening characteristics of the plastic rollers/wheels result in quieter operation. Typical rigid plastic roller/wheel material choices are:

- Acetron® POM Grades
- Nylatron® PA Grades
- Ertalyte® PET-P Grades

Rigid plastics are also replacing traditional resilient elastomers such as polyurethane and vulcanized rubber. The rigid plastics are chosen for their lower coefficient of rolling resistance.

To determine the suitability of a rigid plastic roller/wheel, consider:

- Load upon the roller/wheel
- Speed of the roller/wheel
- Temperature around and on the roller/wheel
- Duty cycle of the roller/wheel – whether it is stationary or rotating
- Creep and fatigue properties of the roller /wheel material

The creep and fatigue properties play an important role in preventing flat spots, cracking and softening of the rollers / wheels in end-use.

The first step in calculating suitability is to determine the load capacity of the proposed material. The load capacity equation is dependent upon the geometry and configuration of the wheels/rollers. Load capacity equations are provided on page 22 for three configurations:

- (1) roller on a flat surface (Figure 20a.)
- (2) roller on another rolling surface (Figure 20b.)
- (3) roller in another rolling surface (Figure 20c.)

Fig. 20

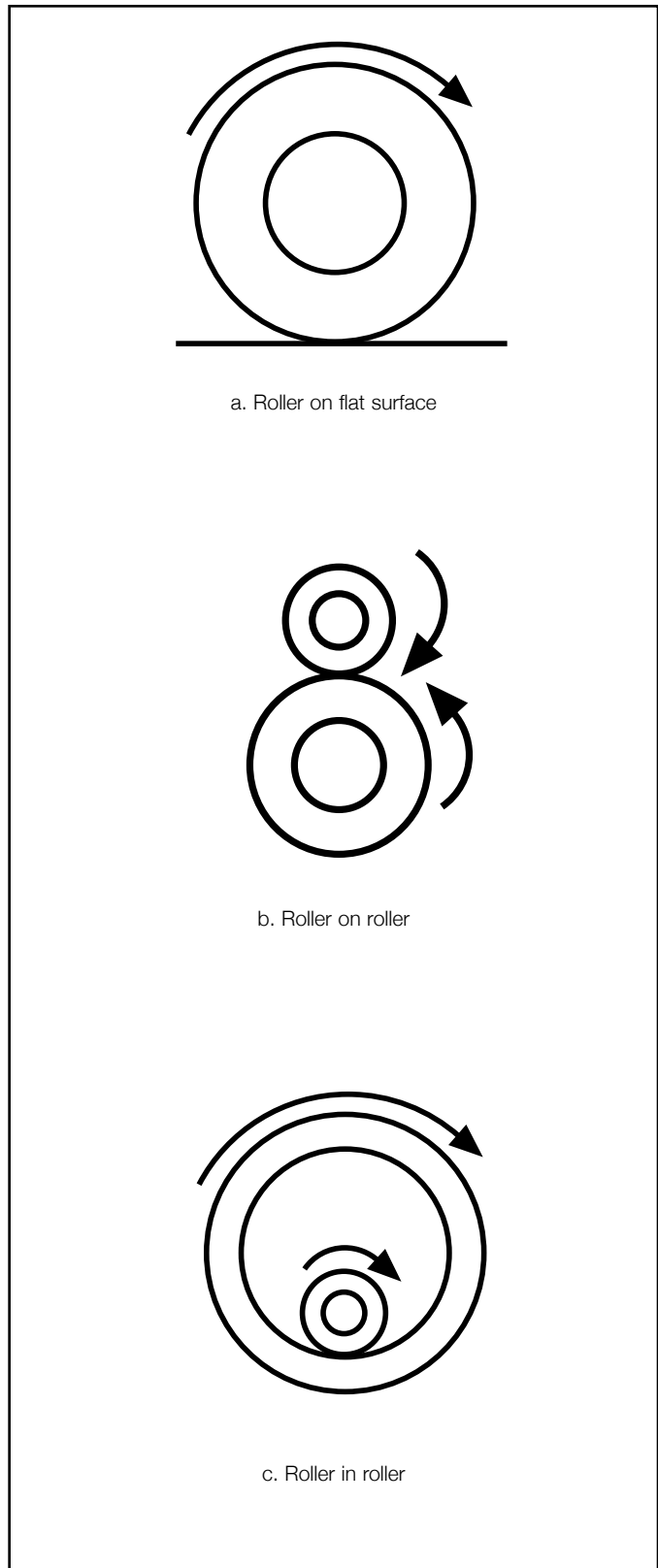

ROLLER/WHEEL DESIGN

Determining the Load Capacity of a Roller/Wheel

Step 1

Select the roller configuration.

1. Roller on a flat surface
2. Roller on another rolling surface
3. Roller in another rolling surface (See Figure 20)

Step 2

Select the potential roller/wheel material.

Step 3

From Table 5, obtain the material stress factor, K.

Note: Separate values are given for stationary vs. rotating situations.

Step 4

Using the equation provided for the selected roller configuration, calculate the load capacity of the roller/wheel.

- (1) Roller on a flat surface (Figure 20a.)

$$W_{MAX} = K (L) (D_p)$$

- (2) Roller on another rolling surface (Figure 20b.)

$$W_{MAX} = K (L) \left(\frac{D_p \times D_m}{D_m + D_p} \right)$$

- (3) Roller in another roller surface (Figure 20c.)

$$W_{MAX} = K (L) \left(\frac{D_p \times D_m}{D_m - D_p} \right)$$

Where:

W_{MAX} = Maximum allowable contact load (lbs.)

D_p = Diameter of plastic roller (in.)

D_m = Diameter of metal roller (in.)

L = Contact length of roller (in.)

DESIGN TIP

Load capacity calculations are purposefully conservative and are based on a 4x safety factor used to determine K. Designers are encouraged to test all rollers and wheels in conditions similar to those anticipated.

Table 5 : Maximum Allowable Contact Stresses (psi)

Material	Material Stress Factor K	
	Stationary	Rotating
Fluorosint® PTFE	5	17
Semitron® ESd 225 POM-C	23	76
Quadrant Nylon 101 PA66	30	99
Nylatron® GSM Blue PA6	32	106
Nylatron® GSM PA6	39	130
Nylatron® NSM PA6	39	130
Techtron® PSBG PPS	42	75
Acetron® POM-H	45	150
Acetron® AF Blend POM-H	45	149
Acetron® GP POM-C	45	150
Nylatron® MC901 / 907 PA6	45	150
Ertalyte® PET-P	46	142
Nylatron® GS PA66	49	162
Techtron® HPV PPS	70	170
Duratron® T4503 PAI	89	157
Duratron® T4301 PAI	91	161
Duratron® T4501 PAI	96	170
Duratron® T4540 PAI	95	170
Ketron® CM PEEK	96	171
Ketron® 1000 PEEK (Extruded)	120	213
Ketron® HPV PEEK	120	171
Ketron® CA30 PEEK	132	234
Duratron® T4203 PAI	168	298
Duratron® CU60 PBI	215	383

Assembly / Fabrication

The three common rigid plastic wheel/roller designs are:

- **Solid rollers rotating directly on the shaft**
- **Solid rollers with ball or roller bearings**
- **Plastic sleeves on metal cores**

See Table 6 for details on the typical uses, advantages, limitations and design/fabrication tips for these typical roller designs.

Fabrication Methods for Plastic Sleeves on Metal Cores

Shrink Fitting

Shrink fitting is the most common assembly method. Shrink fit interference and axial clearance depends upon the roller/wheel's operating temperature. Table 7 contains the interference and clearances for four elevated temperatures. To assemble, heat the plastic sleeve to 200°F.

Quadrant manufactures cast nylon roll covers for shrinking on to metal cores. Cast nylon roll covers are available in diameters up to 25" and in lengths up to 84". To shrink on to core, simply heat the plastic sleeve and metal core to 200°F and assembly with the aid of a hydraulic press.

Casting plastic sleeve on to metal core

Directly casting the nylon plastic sleeve on to the metal core is the most efficient assembly method. It also eliminates slippage between the plastic sleeve and the metal core – the most common issue for shrink fits. Casting on the metal core is ideal for wheels/rollers with face widths less than 1".

Table 7 : Interferences and Clearances at Elevated Temperatures

Average Operating Temperature of Sleeve	Shrink Fit Interference at 68°F (20°C) Value is in % of d	Axial Clearance (b) at 68°F (20°C) Value is in % of sleeve width
100°F (38 °C)	0.25	0.05
140°F (60°C)	0.45	0.20
175°F (80°C)	0.65	0.40
200°F (93°C)	0.85	0.60

Table 6 : Typical Roller/Wheel Designs

Roller/Wheel Design	Typical Use Conditions	Advantages	Limitations	Design/Fabrication Tips
Solid rollers rotating directly on the shaft	Intermittent service Low velocity Low load	Lowest cost	Design must account for moisture and temperature growth	Calculate Limiting PV and required running clearance with bearing design equations Prevent lateral binding by considering the material's moisture and temperature growth when calculating the axial clearance
Solid rollers with press-fit ball or roller bearings	For operating temperatures up to 120°F (49°C)	Quick and easy assembly	Not suitable for side-loaded wheels/rollers	Press-fit made easier by heating-up the plastic roller.
Solid rollers with mechanically fastened snap rings or metal flanges	For operating temperature above 120°F (49°C) For side loaded wheels/rollers	Mechanical fastening prevents axial movement		For rolling element bearings: Prevent axial and circumferential movement by securing the outer race. Press the bearing into the flanged sleeve. Then press in to the wheel/roller. Secure with a bolt through the flange to the roller
Plastic sleeves on metal cores	High loads High temperatures High speeds	Balances the impact resistance of the plastic sleeve with the heat dissipation of the metal core		Make plastic wall thickness 10 to 15% of metal core OD. Contact Quadrant for design options.

[SHEAVE DESIGN

For many years, manufacturers and operators of heavy-duty lifting equipment have sought ways to increase wire rope endurance life. Early attempts included lining the grooves of metal sheaves with resilient materials and mounting rims made of these materials on metal hubs.

Growth in manufacturing of mobile lifting equipment now requires designers to consider reducing the dead weight of metal sheaves on the boom or mast, and improving lift and over-the-road performance. Expansion in offshore exploration has also generated a need for lifting equipment with corrosion resistant parts.

With the development of Nylatron® GSM PA6 cast nylon sheaves, the search for improved wire rope life, reduced weight, and corrosion resistance has been resolved. Nylatron® nylon sheaves are widely used on both mobile and offshore lifting equipment.

Fig. 21

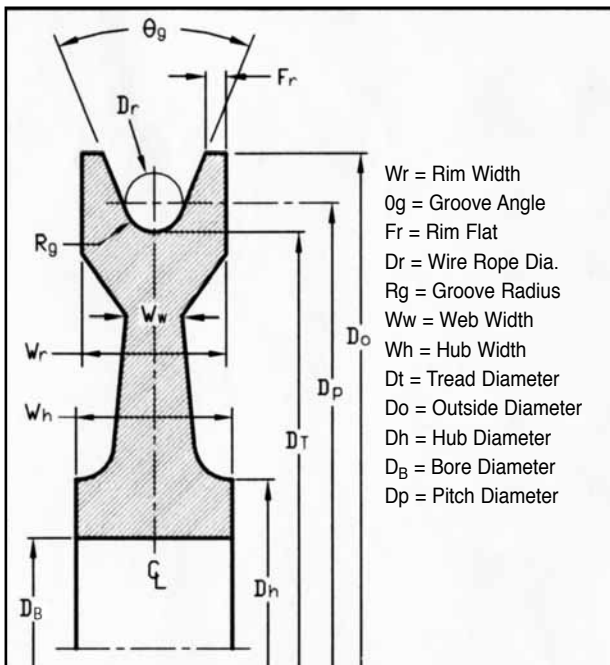

Table 8 : Wire Rope Lift Test Results*

Sheave Ratio	Rope Tension for Test	Design Factor (Fd)	Approximate Duration of Test	Increase in Rope Life Attained with Nylatron® GSM PA6 Sheaves*
24/1	10.0% of breaking strength	10.0	136,000 cycles	4.50 times
24/1	20.0% of breaking strength	5.0	68,000 cycles	2.20 times
24/1	28.6% of breaking strength	3.5	70,000 cycles	1.92 times
18/1	28.6% of breaking strength	3.5	39,000 cycles	1.33 times

Sheave Ratio = D_T/D_r = Sheave pitch diameter/rope diameter

*Conventional rope retirement criteria based only upon visible wire breaks may prove inadequate in predicting rope failure. **The user of Nylatron® nylon sheaves is therefore cautioned that a retirement criteria should be established based on the users' experience and demands of the specific applications.**

NYLATRON® GSM PA6 SHEAVES

→ Support the same load as metal

Stress on the wire rope – not the sheave commonly limits the lifting capacity of a system. The point contact pressure for a steel sheave will be much higher than for a Nylatron® nylon sheave, and the resilience of nylon results in a larger point contact area and created support for the wire rope. Light weight Nylatron® nylon sheaves can support cyclical loads equal to steel sheave capabilities.

→ Reduce Weight

Because Nylatron® GSM PA6 nylon is approximately one seventh (1/7) the weight of conventionally used cast steel, Nylatron nylon sheaves reduce dead weight at the end of the boom. This provides mobile cranes with greater stability and lifting capacity and lower over-the-road weight.

The reduced weight of Nylatron® GSM PA6 sheaves makes handling, installation and replacement significantly easier and safer than with comparable metal sheaves.

→ Extend wire rope life

Quadrant Engineering Plastic Products, in conjunction with a nationally recognized independent research institute, conducted wire rope endurance tests to obtain a comparison of the fatigue life of wire rope used with Nylatron® GSM PA6 sheaves and hardened steel sheaves under the same conditions.

Test results at stress levels of 10%, 20%, and 28.6% of ultimate wire rope strength indicate dramatic improvements in the endurance life of wire rope when used with cast Nylatron® sheaves. Table 8 summarizes results of the wire rope life testing. The tests prove Nylatron® nylon sheaves substantially increase rope cycle life.

→ Resists Corrosion

The corrosion resistant properties of nylon make these plastic parts ideal for marine use.



Design Guidelines

When designing with custom or standard sheaves, certain considerations should be observed by equipment engineers. Of special importance are groove configuration, bore configuration, bearing retention, and load capacity. Figure 21 should help to clarify important parameters. The basic design of any sheave should conform with the appropriate minimum pitch diameter/rope diameter sheave ratios of 18/1 and 24/1 for the mobile crane industry. The 18/1 ratio conforms to the Power Crane and Shovel Associations and American National Standards Institute (ANSI) minimums for load hoisting cranes. The 24/1 ratio complies with most European standards and should be considered for export requirements.

Rim Dimensions

The rim width (W_r) and outside tread diameters (D_o and D_r) are typically fixed design dimensions. The rim flat (Fr-shown in Figure 21) between the groove wall and rim edge should be a minimum of 1/8" to provide adequate side load stability.

Groove Dimensions

The groove radius (R_g) for a Nylatron® nylon sheave should be a minimum of 5% greater than the nominal rope diameter divided by 2 to accommodate rope tolerances while giving adequate rope support.

$$R_g = 1.05 (D_r / 2)$$

Experience indicates that a groove angle (θ_g) of 30° will generally provide optimum rope support for mobile crane sheaves. Unless otherwise specified, Nylatron® nylon sheaves are supplied with a 30° groove angle. Fleet angles up to 4% generally require a 45° groove angle.

Typical American and European practice requires that the depth of the rope groove for mobile crane sheaves be made a minimum of 1.75 times the rope diameter. Nylatron® nylon sheaves are supplied with a corresponding groove depth unless otherwise specified.

Web Dimensions

Practical experience with crane sheaves has shown that the required design strength can be maintained with a minimum web width that is 10% greater than the rope diameter or :

$$W_w = 2.2(R_g)$$

Where:

$$W_w = 1.1 \cdot \text{Groove Diameter}$$

$$R_g = 1.05 \cdot D_r / 2$$

The benefit of reducing the web width is weight savings. Additional strength can be obtained by adding ribs to the design.

Hub Dimensions

The hub width (W_h) is generally a design requirement specified by the end user. In most cases it should be equal to or greater than the rim width for stability of the sheave in use. The minimum hub diameter (D_h) is 1.5 times the bearing outside diameter (D_b) for adequate wall support of the bearing. The wall thickness between the bearing and hub diameter should always be greater than 1".

$$D_h = 1.5(D_b)$$

The transitions from the hub diameter to the web and the web diameter to the rim must be tapered and radiused as appropriate based upon the design thicknesses and diameters.

Bore Dimensions

Nylatron® nylon sheaves for heavy-duty applications should be installed with antifriction bearings. Needle roller bearings are generally recommended as they provide a continuous contact area across the width of the bore. As the coefficient of thermal expansion of nylon is several times that of metal, the press fit allowance must be large enough for the bearing to maintain contact with the bore at temperatures up to 140°F.

$$d = .009 \sqrt{D_b}$$

Where

d = Press fit allowance (in.)

D_b = Bearing outside diameter (in.)

The diameter of the sheave bore will be the O.D. of the bearing minus the press fit allowance.

$$D_B = D_b - d$$

Sufficient press fit is critical to prevent buckling of a loaded sheave.

DESIGN TIPS

Bronze bearings are not recommended for main load applications. Their use should be limited to moderate unit loads to avoid excessive frictional heat build-up and possible movement of the bearing in the bore.

For lightly loaded applications where pressure-velocity (PV) values are not excessive, it may be possible to plain bore Nylatron® nylon sheaves for running directly on the shaft. Contact Quadrant for appropriate running clearance information.

[SHEAVE DESIGN

Bearing Retention

Circumferential bearing retention can be achieved using the press fit allowances (as calculated under bore dimensions) and pressing directly into the bore of the Nylatron® nylon sheave. A hydraulic press can be used, or the sheave can be heated to 180°-200°F and the bearing dropped into the expanded bore.

Thrust washers or thrust plates should be placed on either side of the sheave hub to maintain sideways bearing retention. This is necessary to restrict bearing movement which may occur as the result of side forces encountered during operation.

There are two exceptions to bearing retention using the above procedure:

- **Two-row double-cup tapered roller bearings in heavy-duty sheave applications**
- **Bronze bearings in idler sheaves where the sheave is free to move from side-to-side on a shaft**

Since thrust washers or thrust plates cannot be used, other means of retention must be found to restrict sideways movement of the bearing.

A positive retention method for two-row double-cup tapered roller bearings is to place a steel sleeve insert in the bore of the Nylatron® sheaves into which the cup is pressed. The insert is held in the bore by external retaining rings on each side of the hub.

Positive retention of bronze bearings in Nylatron® idler sheaves can be accomplished by extending the length of the bushing beyond the hub on both sides, and placing external retaining rings on each side of the hub. Metal side plates bolted to the hub and overlapping the ends of the bearing can also be used for this purpose.

DESIGN TIP

- The use of nylon thrust washers or plates where they will wear against the Nylatron® nylon sheave hub is not recommended.
- Calculation of tread pressure is not necessary if the ratio of groove diameter to rope diameter is 18:1 or larger.

A steel sleeve insert, held in the bore by external retaining rings, is recommended with the use of two-row double-cup tapered roller bearings.

Load Capability of Nylatron® Nylon Sheaves (with Bearings)

The following equations can be used to calculate the maximum groove and bore pressure acting on any sheave.

$$P_g = \frac{2(LP_{MAX})K_{\Theta}}{Dr \cdot Dt} \quad (1)$$

$$P_b = \frac{2(LP_{MAX})K_{\Theta}}{Db \cdot Wh} \quad (2)$$

Where:

P_g = Max groove pressure (psi)

P_b = Max bore pressure (psi)

LP_{MAX} = Max single line pull (lb.) or wire rope breaking strength divided by design safety factor

Dr = Rope diameter (in.)

Dt = Tread diameter (in.)

Db = Bore diameter (in.)

Wh = Hub width (in.)

K_{Θ} = Wrap factor = $\sin\left(\frac{\text{wrap angle}}{2}\right)$

Θ = Wrap angle

Table 9 : Wrap Angle Factors

Wrap Angle	*(Included angle)	K_{Θ}
180°	(0°)	1.000
170°	(10°)	0.996
160°	(20°)	0.985
150°	(30°)	0.966
140°	(40°)	0.940
130°	(50°)	0.906
120°	(60°)	0.866
110°	(70°)	0.819
100°	(80°)	0.766
90°	(90°)	0.707
80°	(100°)	0.643
70°	(110°)	0.573
60°	(120°)	0.500

* Arc of groove contacted by rope.

Maximum service pressure can safely reach 8,600 psi for short term loads (a few minutes). Maximum service pressure for static loads (>100 hours) should not exceed 3,500 psi. Equations (1) and (2) can be rewritten to calculate the maximum line pull for a Nylatron® sheave:

$$L_{pMAX} = \frac{1750 (Dr \cdot Dt)}{K_{\Theta}}$$

$$L_{pMAX} = \frac{1750 (Wh \cdot Db)}{K_{\Theta}}$$

Load Capability of Plain Bored Sheaves

The load capacity for a plain bored Nylatron® nylon sheave is based upon the ability of the bore to act as a bearing. To determine the recommended load capacity, refer to the Bearing Design section of this manual, and make calculations as follows assuming that the bore of the sheave is a Nylatron® GSM PA6 nylon bearing.

First, obtain the recommended limiting pressure velocity value (PVa) for the given operating conditions. Next, calculate the maximum bore pressure from the equation:

$$P_b = \frac{PV_a}{V}$$

Where:

- P_b = Maximum bore pressure (psi)
- PV_a = Pressure velocity value (psi • fpm)
- V = Shaft surface speed (fpm)
= 0.262 x shaft rpm x D_s
- D_s = Shaft diameter (in.)

Bore pressure P_b should not exceed 1,000 psi. Take the calculated value for P_b or 1,000 psi, whichever is less, and substitute in the following equation to obtain the maximum load capacity for the conditions specified:

$$LC = P_b \cdot D_s \cdot W_h$$

Where:

- LC = Max load capacity (lbs.)
- W_h = Width of hub in contact with shaft (in.)

DESIGN TIPS

Contact Quadrant for special design requirements including underwater cable systems, V-belt applications, high temperature, sheave ratios below 18:1, fleet angles greater than 3°, or severe chemical environments.

Industries that use sheaves for power transmission or load lifting applications typically have other bearing and wear requirements that could also benefit from the use of products from Quadrant Nylatron® nylon's wear and impact resistance, light weight, and corrosion resistance present unique advantages in a wide variety of wear and structural components (i.e. slide bearings, wire guides, bushings, rollers and roll covers).

The pressure and load capacity limits recommended above are based on intermittent cyclical loading as in typical mobile hydraulic crane operation. If operation involves continuous cycling or loading, high speed and acceleration, or heavy impact forces, the limits should be reduced and the application thoroughly evaluated. Excessive loads and/or speeds may cause distortion of the bore and loss of press fit with the bearing. Accelerated groove wear may also result. For plain bored sheaves, excessive loads and/or speeds may cause accelerated wear and increased clearance in the bore.

Sheave Design Worksheet

INFORMATION REQUIRED

Maximum single line pull (Load) _____ lbs.
 Line speed _____ ft./min.
 Fleet angle _____ degrees
 Temperature low _____ °F high _____ °F
 Arc of sheave contacted by rope _____ °

SHEAVE DATA

Drawing Number? _____
 If no drawing is available...
 W_r Rim width _____ inches
 D_o Outer diameter _____ inches
 D_t Tread diameter _____ inches
 D_h Center hub O.D. _____ inches
 W_h Hub width _____ inches
 D_b Center bore I.D. _____ inches
 Alignment or access holes required?

 Number? _____
 Pitch Circle? _____
 Grease fittings? _____
 Type? _____
 Location? _____

WIRE ROPE DATA

Rope O.D. _____ inches
 Rated breaking strength _____
 Brand of rope in use _____

BEARING SPECIFICATIONS

Design _____
 Mfr / Part Number _____
 O.D. of outer race _____ inches
 Bearing width _____ inches
 Method of attachment _____

IF YOU REQUIRE ANY FURTHER ASSISTANCE OR A QUOTE, PLEASE FAX THIS SHEET OR YOUR APPLICATION INFORMATION TO QUADRANT TECHNICAL SERVICES AT 610-320-6866.

[GEAR DESIGN

Engineering plastics gears offer:

- quiet operation
- ability to run without lubrication
- reduced inertia versus traditional all metal gears
- corrosion resistance

Nylatron® and MC® nylons have been successfully used for spur, worm, bevel and helical gears for 25 years. Today, in a variety of industries, plastic gears continue to replace:

- steel
- wood
- bronze
- cast iron
- phenolic

Nylatron® nylon balances strength, heat resistance, fatigue properties, impact resistance and wear resistance, making it the most popular choice for gearing. Acetal, TIVAR® UHMW-PE and new higher performance materials offer specific advantages for wet/high humidity conditions, chemically aggressive environments, light-duty service or high temperature applications.

Nylatron® Nylon as a Replacement for Metal Gears

Although nylon has significantly lower strength than a corresponding metal gear, reduced friction and inertia coupled with the resilience (bending) of thermoplastic gear teeth make direct substitution possible in many applications – especially gears made from nonferrous metals, cast iron and unhardened steel.

A step-by-step method for evaluating suitability of nylon spur gears is provided here.

This method was developed using Quadrant's gear fatigue test data, and the maximum allowable bending stress of plastic gear teeth (see Figure 23). In addition, four correction factors are provided which account for:

- Material strength and the presence or absence of lubrication
- Pitch line velocity
- Required service life
- Ambient temperature under service conditions

Fig. 22

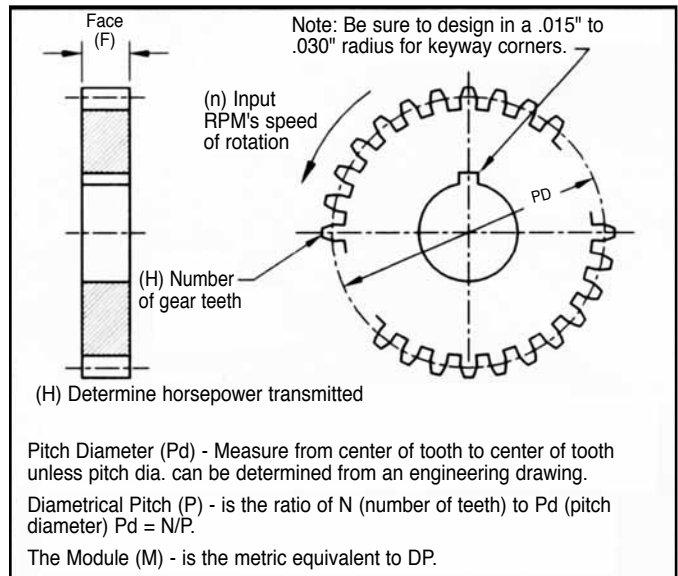

Gear Design Method

Step 1

- Obtain the Required Application Data
- Diametrical Pitch, P
 - Number of Teeth, N
 - Pressure Angle, PA
 - Face Width, inches, F
 - Input RPMs, n
 - Input Torque, T_i
 - OR Input Horsepower, HP_i

Fig. 23 - MAXIMUM TOOTH BENDING STRESSES VS. CYCLE LIFE FOR NYLON GEARS

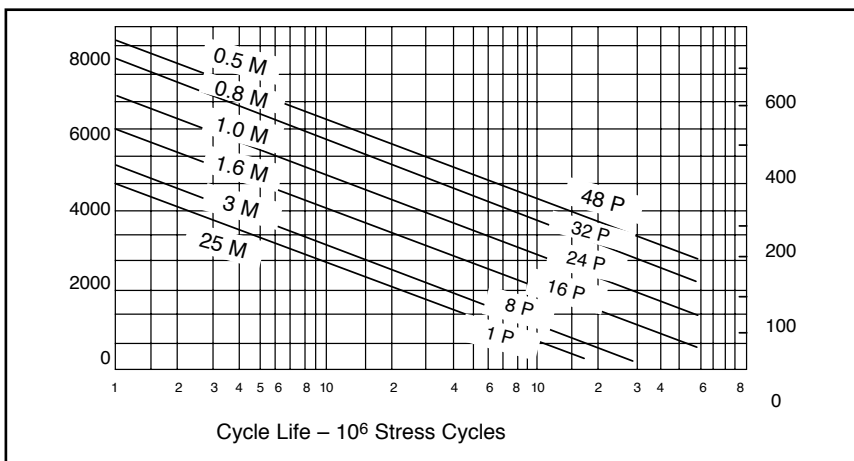



Table 10 : Tooth Form Factor

Number of Teeth	14 1/2°	20° Full Depth	20° Stub
14	–	–	0.540
15	–	–	0.566
16	–	–	0.578
17	–	0.512	0.587
18	–	0.521	0.603
19	–	0.534	0.616
20	–	0.544	0.628
22	–	0.559	0.648
24	0.509	0.572	0.664
26	0.522	0.588	0.678
28	0.535	0.597	0.688
30	0.540	0.606	0.698
34	0.553	0.628	0.714
38	0.566	0.651	0.729
43	0.575	0.672	0.739
50	0.588	0.694	0.758
60	0.604	0.713	0.774
75	0.613	0.735	0.792
100	0.622	0.757	0.808
150	0.635	0.779	0.830
300	0.650	0.801	0.855
Rack	0.660	0.823	0.881

Step 2

Obtain the Derived Data and Correction Factors

Pitch Diameter, Pd = N/P

Tooth Form Factor, y - From Table 10

Bending Stress, S_b - From Table 11

Service Lifetime Factor, C_s - From Table 12

Velocity Factor, C_v - From Table 13

Material Strength Factor, C_m - From Table 14

Temperature Correction Factor, C_T

- For ambient temperature <100°F, C_T = 1
- For ambient temperature between 100°F and 200°F, C_T = 1/(1 + α (T-100°F))

Where α = 0.022 for Nylatron® GSM, NSM, and MC® nylons
 α = 0.004 for Nylatron® GS and Quadrant Nylon 101 PA66
 α = 0.010 for Acetron® GP POM-C

Step 3

Calculate the Maximum Torque or Horsepower using Equations (1) and (2)

Maximum Torque

$$T_{MAX} = \frac{Pd S_b f y}{2P} C_s C_v C_m C_T \quad \text{(Equation 1)}$$

$$HP_{MAX} = \frac{Pd S_b f y n}{126,000 P} C_s C_v C_m C_T \quad \text{(Equation 2)}$$

Table 11 : Bending Stresses

Pitch	S _b
2	1994
3	2345
4	2410
5	2439
6	2675
8	2870
10	3490
12	3890
16	4630
20	5005

Table 12 :Life Factors for Nylatron® Nylon Spur Gears

Number of Cycles	16 pitch	10 pitch	8 pitch	5 pitch
1 million	1.26	1.24	1.30	1.22
10 million	1.00	1.00	1.00	1.00
30 million	0.87	0.88	0.89	0.89

Table 13 : Velocity Correction Factors

Velocity-fpm	Correction Factors
500	1.38
1000	1.18
2000	1.00
3000	0.93
4000	0.90
5000	0.88

Table 14 : Material Strength Factor

Material	Operating Conditions		
	Non-Lubrication	Periodic Lubrication	Continuous Lubrication
Nylatron® NSM PA6	1.00	1.00	1.20
Nylatron® GS, GSM PA6	0.49	0.94	1.26
Nylatron® MC901/907 PA6	0.49	0.94	1.26
Acetron® GP POM-C	*	*	1.04
Phenolic	*	0.96	1.13
TIVAR® UHMW-PE	*	*	0.75

* Data not available.

Step 4

Compare the maximum torque (T_{MAX}) and maximum horsepower (H_{MAX}) values for the plastic gear with the known input torque (T_I) and/or horsepower (H_I).

T_I must be less than or equal to T_{MAX}
or
H_I must be less than or equal to H_{MAX}

If T_I and H_I exceed the T_{MAX} and H_{MAX} for the plastic gear, select another material or another pitch diameter and face width and re-calculate using the new material correction factors.

[GEAR DESIGN

Helical Gears

To determine the stress on plastic helical gears, spur gear design equations 1 and 2 are modified to compensate for the differing tooth contact forces. The tooth form factor Y is calculated from the formative number of teeth rather than the actual number using the equation:

$$N_f = \frac{N}{(\cos U)^3}$$

Where:

N_f = Formative number of teeth

N = Actual number of teeth

U = Helix angle (degrees)

In addition, the normal diametral pitch is used rather than the diametral pitch used for spur gears in equations (1) and (2). This is calculated from:

$$PN = \frac{P}{\cos U}$$

Where:

PN = Normal diametral pitch

It can be seen from these equations that the effect is more pronounced as the helix angle increases. Metal helical gears are often specified to reduce noise and vibration and it should be noted that the equivalent plastic spur gears will achieve these reductions more efficiently.

Bevel Gears

For bevel gears, the tooth form factor y is calculated using the formative number of the teeth using the equation:

$$N_f = \frac{N}{\cos \emptyset}$$

Where:

\emptyset = Pitch angle, degrees

It should be noted that Diametral Pitch and Pitch Diameter used in equations (1) and (2) refer to the outside or larger tooth dimensions of bevel gears.



Assembly

Gears are commonly fastened to shafts using a variety of techniques including:

- **Press fit over splined and or knurled shafts for gears transmitting low torques**
- **Set screws for an economical low torque gear**
- **Bolting a metal hub through the gear width is suitable for drive gears produced in small to intermediate quantities**
- **Machined keyways for gears carrying higher torques. The use of radiused keyways is preferred to square to reduce the stress concentration at the corners. The minimum corners keyway area is determined from the formula:**

$$A = \frac{63,000 \text{ HP}}{n r S_k}$$

Where:

- A = Keyway area
- HP = Horsepower transmitted
- n = Gear speed (rpm's)
- r = Mean keyway radius
- S_k = Maximum permissible keyway stresses from Table 15

Table 15 : Maximum Permissible Keyway Stress (S_k) for Continuously Running Gears

Material	S _k (psi)
Nylatron® GS PA66	1,500
Nylatron® PA66	1,500
Nylatron® GSM/MC901 PA6	2,000
Acetron® POM	2,000
TIVAR® UHMW-PE	300

If the keyway size determined from the equation above is impractical and multiple keyways cannot be used, then a keyed flanged hub and check plate bolted through the gear should be used. The required number of bolts and their diameters at a particular pitch circle radius is calculated from a modified form of the equation.

Minimum number of bolts =

$$\frac{63,000 \text{ HP}}{n r_1 A_1 S_k}$$

Where:

- r₁ = Pitch circle radius of bolts
- A₁ = Projected area of bolts (bolt diameter x gear width in contact with bolts)

Raise fractional values to the next highest number of bolts. Should not be excessively tightened during assembly of the gear in order to avoid the risk of gear distortion or bolt shearing due to material expansion during normal running. Consequently, the use of cup washers or similar are recommended where practical, although nylon washers provide a satisfactory alternative.

DESIGN TIPS

- Heat dissipation and therefore performance is optimized by running plastic gears against metal gears. When running an all plastic gear system dissimilar materials are suggested (e.g. nylon with acetal).
- Sufficient backlash is required for plastic gears to accommodate the greater thermal expansion of plastic versus metal due to frictional heating and changes in ambient conditions. The suggested backlash can be calculated using:

$$\text{Backlash} = \frac{0.100}{P} \text{ (diametrical pitch)}$$

- The lack of proper backlash is the most common cause of nylon gear failure. Backlash should be checked on installation through a full rotation of the nylon gear.
- A 20° pressure angle with a full root radius maximizes the bending strength of gear teeth over 14-1/2° pressure angles. This increases the load carrying capability by 15% over 14-1/2° pressure angle, or increases service life 3.5 times at the same load.
- Where design permits select the smallest tooth that will carry the load required. This will minimize heat build-up from higher teeth sliding velocities.
- For higher torque capability, consider gear blanks directly cast over machined steel inserts.
- Nylatron® nylon gears are generally superior to other engineering plastics provided environmental factors such as temperature, humidity and chemicals are within its usable limits. The choice of material depends on both environmental and operational running conditions.
- The wear of a plastic gear is largely determined by the counterface, or opposing gear. In general, it is best to avoid making both driven and driving gears from similar plastics. Most plastic gears wear well against metal. A surface finish of 12-16 μ in. min. is recommended on metal gears running against plastic gears.
- Nylatron® nylon does absorb some moisture, and will therefore increase slightly in size. However, most gears are of such a heavy section that moisture pickup is extremely slow and does not require any special consideration when designing the gear. Again, increased backlash compensates for growth due to moisture.

If the Nylatron® gear is to be completely immersed in water, it is suggested that Quadrant EPP be contacted directly for design assistance.

CHEMICAL DATA

The following chemicals and fluids are known to attack or be compatible with the Quadrant materials given. Chemical effects are at room temperature. Use this chart as a general guide only. Contact Quadrant for further information.

Chemical	Concentration Weight, %	PROTEUS® PP	PROTEUS® HDPE / LDPE	TIVAR® UHMW-PE	Nylons		Acetron® GP POM-C / Acetron® POM-H	Eralyte® PET-P / Eralyte® TX PET-P	Quadrant PC 1000	Quadrant PSU	Duratron® U1000 PEI	Fluorosint® PTFE	SYMALIT® PVDF / ECTFE	Tecitron® PPS	Ketron® 1000 PEEK	Duratron® PAI	Duratron® PI	Duratron® CU60 PBI
					Nylatron® PA66	Nylatron® PA6												
Acetaldehyde Aq.	40	B	A	B	B	B	A	A	D	*	D	A	C	A	A	A	*	*
Acetamide Aq.	50	A	A	*	A	A	A	*	*	*	*	A	A	*	A	A	*	*
Acetic Acid Aq.	10	A	A	A	C	C	C	B	B	A	A	A	A	A	A	A	D	B
Acetone		A	D	A	A	A	A	B	D	D	C	A	A	A	A	A	A	A
Acrylonitrile		A	A	*	A	A	*	B	D	D	*	A	B	A	A	A	*	A
Alcohols, Aliphatic		A	A	A	B	B	A	A	A	A	A	A	A	A	A	A	*	*
Allyl Chloride		B	B	A	C	*	*	*	*	*	*	A	A	*	A	*	*	*
Allyl Alcohol		B	B	A	*	B	*	A	B	*	*	A	A	A	A	A	*	*
Aluminum Chloride Aq.	10	A	A	A	A	A	*	A	A	*	*	A	A	A	A	A	B	*
Aluminum Sulfate Aq.	10	A	A	A	A	A	A	*	A	A	*	A	A	A	A	A	B	*
Ammonia Aq.	10	A	A	A	A	A	A	C	*	*	*	A	B	A	A	B	D	C
Ammonia Gas		A	A	*	C	B	D	A	D	B	*	A	A	*	A	C	D	C
Ammonium Carbonate Aq.	10	A	A	A	A	A	*	A	B	*	*	A	A	A	A	A	*	*
Ammonium Chloride Aq.	10	A	A	A	D	B	A	A	A	A	*	A	A	A	A	A	*	*
	37	A	A	A	D	B	A	A	A	*	*	A	A	A	A	A	*	*
Amyl Acetate		D	A	A	B	D	A	*	D	D	B	A	B	A	A	A	*	*
Amyl Alcohol		A	A	A	*	A	*	*	B	A	*	A	A	A	A	A	*	*
Aniline		A	A	A	C	C	B	A	C	*	*	A	B	A	A	A	D	*
Antimony Trichloride Aq.	10	A	A	A	D	D	*	*	A	D	*	A	A	*	A	*	*	*
Barium Chloride Aq.	10	A	A	A	D	B	A	A	A	A	*	A	A	A	A	A	*	*
Barium Sulfate Aq.	10	B	A	A	*	A	A	*	*	*	*	A	A	*	A	A	*	*
Barium Sulfide Aq.	10	A	A	A	A	*	*	*	*	*	*	A	A	*	A	A	*	*
Benzaldehyde		A	A	A	A	C	A	A	D	*	D	A	B	B	A	A	*	*
Benzene		C	C	C	A	A	A	A	D	D	D	A	B	A	A	A	A	*
Benzenesulfonic Acid		B	D	A	D	*	C	*	D	*	*	A	B	A	D	D	*	*
Benzyl Alcohol		A	A	A	C	D	A	A	D	*	*	A	A	A	A	A	*	*
Benzoic Acid Aq.	SAT	A	A	A	C	D	*	A	D	*	*	A	A	A	A	*	B	*
Beverages Aq. Alcoholic		A	A	A	B	B	A	A	A	A	A	A	A	A	A	A	*	A
Beverages Aq. Carbonated		A	A	A	B	B	A	A	A	A	A	A	A	A	A	A	*	A
Bitumen		*	A	*	B	B	A	*	*	*	*	A	*	*	A	*	*	*
Bleaching Lye	10	A	A	A	C	B	C	*	*	*	*	A	B	*	A	A	*	*
	100	A	A	A	C	B	C	*	*	*	*	A	C	*	A	*	*	*
Boric Acid Aq.	10	A	A	A	D	D	*	A	A	*	*	A	A	A	A	*	B	*
Boron Trifluoride		*	A	*	D	D	D	*	*	*	*	*	A	*	B	C	*	*
Bromine Aq.	30	D	D	D	D	D	D	*	D	A	*	A	A	A	B	A	*	*
Bromine Liq.		D	D	D	D	D	D	*	D	*	*	*	A	A	D	B	*	*
Butanol		A	A	A	B	B	A	A	B	A	A	A	A	A	A	A	A	A
Butyl Acetate		B	D	A	A	B	A	A	D	D	B	A	B	A	A	A	*	*
Butyl Phthalate		B	A	A	D	*	*	*	*	*	*	A	*	B	A	A	*	*
Butylene Glycol		*	A	*	A	B	A	B	B	*	A	A	*	A	A	*	*	A
Butylamine		B	*	*	A	*	D	*	D	*	D	A	D	B	A	A	*	*
Butyric Acid Aq.	20	A	B	A	D	B	A	*	D	*	*	A	A	A	A	*	B	*
Butyric Acid	CONC	A	B	A	D	B	*	*	D	*	*	A	A	A	A	*	B	*
Butyrolactone		*	*	*	*	A	A	B	C	*	*	A	*	*	A	A	*	*
Calcium Chloride Aq.	10	A	A	A	D	A	A	A	A	A	*	A	A	A	A	A	B	*
Calcium Chloride (in Alcohol)	20	A	A	A	D	D	A	*	*	*	*	A	*	A	A	*	*	*
Calcium Hypochlorite		A	A	A	D	D	D	A	A	B	*	A	A	A	A	A	*	*
Camphor		C	C	*	A	A	A	*	*	*	*	A	B	A	A	*	*	*
Carbon Disulphide		D	B	D	A	A	A	*	D	*	*	A	A	A	A	*	A	*
Carbon Tetrachloride		D	B	C	A	A	A	A	D	A	A	A	A	A	A	A	*	A
Carbonic Acid Aq.	10	A	A	A	A	*	A	A	*	*	*	A	A	A	A	*	A	*
Carnalite Aq.	10	*	*	*	*	A	*	*	*	*	*	A	*	*	A	*	*	*
Castor Oil		A	A	A	A	*	A	A	A	*	*	A	*	A	*	A	*	*
Catechol		*	*	*	*	C	*	*	*	*	*	*	*	*	A	*	*	*
Chloroacetic Acid Aq.	10	A	B	D	D	C	D	*	*	*	*	A	A	A	A	*	C	*
Chloral Hydrate		B	A	A	D	D	*	*	*	*	*	A	A	*	A	*	*	*
Chlorine Aq.	10	D	D	B	D	D	D	D	D	D	D	A	A	D	D	D	*	D
Chlorine Dioxide		C	D	B	D	D	D	*	D	D	*	D	B	*	D	*	*	*
Chlorine Gas	100	C	D	B	*	D	D	*	B	*	*	A	A	*	A	*	A	A
Chlorobenzene		D	D	B	A	A	A	A	D	D	*	A	A	A	A	A	B	*
Chloroform		C	D	D	A	C	C	D	D	D	D	A	A	A	A	A	*	A
Chlorosulfonic Acid Aq.	10	A	A	*	D	C	D	*	*	*	*	A	A	D	D	*	*	*
Chrome Alum Aq.	10	A	A	A	A	*	*	*	A	*	*	A	A	*	A	*	D	*
Chromic Acid Aq.	1	A	A	A	D	C	B	A	A	A	A	A	A	A	A	A	A	*
Citric Acid Aq.	10	A	A	A	B	B	A	A	A	A	A	A	A	A	A	A	B	A
	SAT	*	*	*	C	C	*	A	*	A	*	A	A	A	A	B	D	*

The chemical resistance of plastics can be difficult to predict. It is dependent upon: temperature, time of exposure, chemical concentration, and stress on the material. Increases in any of these factors may result in reduced chemical inertness. This table is intended as a guide only, and not intended as an alternative to actual testing. Quadrant recommends actual testing which represents the only method for evaluating suitability for use.

Chemical	Concentration Weight, %	PROTEUS® PP	PROTEUS® HDPE / LDPE	TIVAR® UHMW-PE	Nylons		Acetron® GF POM-C, Acetron® POM-H	Ertalve® PET-P	Ertalve® TX PET-P	Quadrant PC 1000	Quadrant PSU	Duratron® U1000 PEI	Fluorosint® PTFE	SYMALIT® PVDF / ECTFE	Techtron® PPS	Ketron® 1000 PEEK	Duratron® PAI	Duratron® PI	Duratron® CU60 PBI
					Nylatron® PA66	Nylatron® PA6													
Coconut Oil		A	A	*	A	A	*	*	*	*	*	*	A	A	A	A	*	*	*
Creosote		*	B	*	A	A	*	*	*	D	*	*	A	*	*	A	*	*	*
Cresols		D	B	*	D	D	*	*	*	D	D	*	A	A	A	A	*	C	*
Cresylic Acid		D	D	A	D	*	*	*	*	*	*	*	A	A	*	A	*	*	*
Cupric Chloride Aq.	10	A	A	*	D	*	A	A	A	A	*	*	A	A	A	A	B	*	*
Cupric Sulfate Aq.	0.5	*	A	*	A	B	A	A	A	*	*	*	A	A	A	A	B	*	*
	10	*	A	*	B	B	*	*	*	*	*	*	A	A	A	A	B	*	*
	SAT	*	A	*	B	B	*	*	*	*	*	*	A	A	A	A	B	*	*
Cyclohexane		C	A	A	A	A	A	A	B	B	A	A	A	A	A	A	A	*	A
Cyclohexanol		B	A	A	B	B	A	A	C	A	A	A	A	A	A	A	A	*	A
Cyclohexanone		D	B	A	A	A	A	A	D	D	*	A	B	A	A	A	A	*	A
Decalin		D	A	*	A	A	B	B	A	A	A	A	B	A	A	A	*	*	A
Detergents, Organic		A	A	A	A	A	A	A	A	A	A	A	A	A	A	A	A	*	A
Dibutylphthalate		A	A	A	A	A	*	*	D	*	B	A	B	*	A	A	*	*	*
Dichlorodifluoro Methane		A	B	*	A	A	A	A	D	D	D	A	A	B	A	A	*	*	A
Dichloroethylene		A	C	D	A	A	B	B	D	D	D	A	A	*	A	A	*	A	A
Diethyleneglycol Aq.	90	A	A	*	A	B	A	A	A	B	*	A	A	*	A	A	*	*	*
Diesel Oil		A	A	A	A	A	A	A	A	A	A	A	A	A	A	A	A	*	A
Dimethyl Carbinol		*	*	*	A	B	*	*	*	*	*	*	A	*	*	A	*	*	*
Dimethyl Aniline		*	*	*	A	*	B	B	D	D	D	A	B	A	A	A	*	*	*
Dimethyl Formamide		A	A	A	A	A	A	A	D	D	D	A	C	A	A	A	*	D	*
Dioxane		C	C	*	A	A	A	A	D	D	*	A	C	A	A	A	*	*	*
Edible Oils		A	A	A	A	A	A	A	A	B	A	A	A	A	A	A	A	A	A
Ethanol, Denatured	96	A	A	*	B	B	A	A	A	A	A	A	B	A	A	A	*	*	A
Ether, Diethyl		D	B	A	A	A	A	A	A	A	A	A	A	A	A	A	*	*	A
Ethyl Acetate		A	B	A	A	A	A	A	D	D	B	A	B	A	A	A	A	*	A
Ethyl Butyrate		B	C	*	A	*	*	*	D	D	B	A	*	*	A	A	*	*	*
Ethyl Chloride		D	D	*	A	*	*	*	*	*	*	A	A	A	A	A	A	*	*
Ethylene Chlorohydrin		D	B	*	D	D	D	D	D	*	*	A	A	A	A	A	*	*	*
Ethylene Chloride		C	C	B	B	B	C	C	C	C	C	A	B	A	A	A	A	A	A
Ethylene Diamine		A	B	A	B	A	*	*	C	B	C	A	B	D	A	D	*	*	*
Ethylene Dichloride		B	D	C	B	D	D	D	D	*	D	A	A	B	A	A	A	A	A
Ethylene Glycol Aq.	96	A	A	A	A	B	A	A	B	A	D	A	A	A	A	A	A	B	A
Ethylene Propionate		*	*	*	A	*	*	*	*	*	*	A	*	*	A	A	*	*	*
Ferric Chloride Aq.	5	A	A	A	B	B	A	A	A	A	*	A	A	A	A	A	A	A	*
	10	A	A	A	B	*	*	*	A	A	*	A	A	A	A	B	A	B	*
	SAT	A	A	A	C	C	*	*	*	*	*	A	A	A	A	B	A	B	*
Ferrous Chloride Aq.	10	A	A	A	B	C	*	*	*	*	*	A	A	A	A	A	A	*	*
Fluorine		D	B	D	D	D	C	C	*	*	*	C	B	*	A	D	C	*	*
Fluosilicic Acid Aq.	10	A	A	A	D	C	*	*	A	*	*	B	A	A	A	C	*	*	*
Fluothane		*	*	*	A	A	*	*	*	*	*	A	*	*	A	*	*	*	*
Freon 12 (Arcton 12)		C	C	*	A	A	A	A	D	A	*	A	A	B	A	*	A	A	A
Formaldehyde Aq.	10	A	A	A	A	B	A	A	A	C	A	A	A	A	A	A	A	B	*
Formic Acid Aq.	3	A	A	A	D	D	B	B	A	*	A	A	A	A	A	B	C	A	D
	10	C	B	A	D	D	C	C	B	D	A	A	A	A	B	C	A	D	D
Fruit Juices	CONC	A	A	A	A	B	A	A	A	A	*	A	A	A	A	A	A	A	A
Furfural		D	D	A	A	B	*	*	*	D	*	A	B	A	A	B	*	*	*
Gasoline		C	A	A	A	A	A	A	A	D	B	B	A	A	A	A	A	A	A
Glycerine		A	A	A	A	B	A	A	A	B	*	A	A	A	A	A	A	*	*
Heptane		B	D	A	A	A	A	A	A	A	A	A	A	A	A	A	A	*	A
Hexane		B	D	A	A	A	A	A	A	B	A	A	A	A	A	A	A	*	A
Hydrobromic Acid Aq.	10	A	A	A	D	C	*	*	*	B	*	A	A	B	D	A	B	*	*
Hydrochloric Acid Aq.	0.4	A	A	A	B	B	A	A	A	A	A	A	A	A	A	A	A	B	B
	2	A	A	A	C	D	B	B	A	A	A	A	A	A	A	A	A	C	D
	10	A	A	A	D	D	C	C	A	A	A	A	A	B	A	A	A	C	D
Hydrofluoric Acid Aq.	4	A	A	A	D	C	B	B	A	A	*	C	A	B	D	*	B	*	*
Hydrogenated Vegetable Oils		A	A	A	A	A	A	A	*	*	*	A	A	A	A	A	A	*	A
Hydrogen Peroxide Aq.	0.5	A	A	A	D	*	A	A	A	A	A	A	A	A	A	*	*	*	A
	1	A	A	A	D	C	A	A	A	A	A	A	A	A	A	A	*	*	A
	3	A	A	A	D	C	A	A	A	A	A	A	A	A	A	A	*	*	A
Hydrogen Sulfide Aq.	SAT	A	A	A	C	C	C	C	A	*	*	A	A	A	A	A	*	B	*
Hydroquinone		A	A	A	B	B	*	*	*	*	*	A	A	*	A	*	*	*	*
Iodine (in Alcohol)		A	B	A	D	D	*	*	D	*	*	A	A	*	A	*	*	*	*
Iodine (in Pt. Iodine) Aq.	3	A	B	A	D	C	*	*	D	*	*	A	A	*	A	*	*	*	*
Iso octane		A	A	A	A	A	A	A	A	B	B	A	A	A	A	A	A	*	A
Isopropyl alcohol		A	A	A	B	B	A	A	A	B	A	A	A	A	A	A	A	A	A
Isopropyl Ether		B	B	A	A	A	A	A	A	C	A	A	A	A	A	A	A	*	A
Lactic Acid Aq.	10	A	A	A	A	A	A	A	A	A	*	A	A	A	A	A	A	A	*
	90	A	A	A	C	D	*	*	*	*	*	A	A	A	A	A	A	B	*
Lead Acetate Aq.	10	A	A	A	B	B	*	*	*	*	*	A	A	A	A	A	A	*	*
Lead Stearate		*	*	*	A	A	*	*	*	*	*	A	*	*	A	*	*	*	*
Linseed Oil		A	B	A	A	A	A	A	A	A	*	A	A	A	A	A	A	*	*
Lithium Bromide Aq.	50	*	A	*	D	D	A	A	*	*	*	A	A	*	A	*	*	*	*

The following chemicals and fluids are known to attack or be compatible with the Quadrant materials given. Chemical effects are at room temperature. Use this chart as a general guide only. Contact Quadrant for further information.

Chemical	Concentration Weight, %	PROTEUS® PP	PROTEUS® HDPE / LDPE	TIVAR® UHMW-PE	Nylons		Acetron® GP POM-C Acetron® POM-H	Eralyte® PET-P Eralyte® TX PET-P	Quadrant PC 1000	Quadrant PSU	Duratron® U1000 PEI	Fluorosint® PTFE	SYMALT® PVDF / ECTFE	Techtron® PPS	Ketron® 1000 PEEK	Duratron® PAI	Duratron® PI	Duratron® CU60 PBI
					Nyatron® PA66	Nyatron® PA6												
Lubricating Oils (Petroleum)		B	B	A	A	A	A	A	A	A	A	A	A	A	A	A	A	A
Magnesium Chloride Aq.	10	A	A	*	A	A	A	A	A	A	*	A	A	A	A	A	*	*
Magnesium Hydroxide Aq.	10	A	A	A	A	A	A	B	*	*	*	A	A	A	A	D	*	*
Magnesium Sulfite Aq.	10	A	A	A	A	A	A	*	*	*	*	A	A	A	A	A	*	*
Maleic Acid Aq.	CONC	A	B	A	*	C	*	*	*	*	*	A	A	*	A	*	*	*
Malonic Acid Aq.	CONC	*	*	*	*	C	*	*	*	B	*	A	*	*	A	*	*	*
Manganese Sulfate Aq.	10	A	A	*	A	A	A	A	A	*	*	A	A	*	A	*	*	*
Mercuric Chloride Aq.	6	A	A	*	C	D	B	A	A	*	*	A	A	*	A	*	*	*
Mercury		A	A	A	A	A	A	A	A	*	*	A	A	A	A	*	*	*
Methanol		A	A	A	A	B	A	A	B	B	A	A	A	A	A	*	*	A
Methyl Acetate		B	C	A	A	A	A	A	D	*	B	A	*	A	A	A	*	*
Methyl Ethyl Ketone		A	B	B	A	A	B	A	D	B	D	B	C	B	A	A	*	A
Methylpyrrolidone		*	A	*	A	A	*	*	*	D	*	A	C	A	A	*	C	*
Methylene Chloride		C	C	B	B	B	C	D	D	D	C	A	A	A	A	A	C	C
Methyl Phenyl Ether		*	*	A	A	*	*	A	*	*	*	A	*	A	A	A	*	*
Milk		A	A	A	A	A	A	A	A	A	A	A	A	A	A	A	*	A
Mineral Oils		A	A	A	A	A	A	*	A	A	A	A	A	A	A	A	A	A
Naphthalene		A	A	A	A	A	A	A	D	D	D	A	A	A	A	*	*	*
Nickel Sulfate Aq.	10	A	A	A	A	A	*	*	A	*	*	A	A	A	A	*	*	*
Nicotine		A	A	*	D	D	*	*	*	*	*	*	A	*	A	*	*	*
Nitric Acid Aq.	0.1	A	A	A	C	C	D	B	A	A	A	A	A	A	A	A	*	B
	10	A	A	A	D	D	D	C	A	C	A	A	A	B	A	A	D	C
Nitrobenzene		A	A	A	C	B	B	D	D	D	D	A	A	A	A	A	C	*
Nitromethane		A	A	A	A	B	*	B	A	D	*	A	A	A	A	A	*	*
Oleic Acid		B	B	A	A	A	A	A	A	A	*	A	A	A	A	*	*	*
Oxalic Acid Aq.	10	A	A	A	C	B	C	*	A	A	*	A	A	A	A	*	*	*
Ozone		D	*	C	C	C	C	C	D	A	*	A	A	C	A	*	A	*
Paraffin		A	A	A	A	A	A	A	A	A	A	A	A	A	A	A	*	A
Perchloroethylene		C	C	B	B	B	B	A	C	*	C	A	A	A	A	A	A	A
Perchloric Acid Aq.	10	C	C	A	D	C	C	A	*	*	*	A	A	*	A	*	*	*
Petroleum Ether		A	C	B	A	A	A	*	A	*	*	A	A	A	A	A	*	*
Phenol Aq.	6	B	B	B	D	D	D	A	D	*	*	A	A	*	B	*	*	A
	75	B	B	B	D	D	D	C	D	D	D	A	A	*	D	*	*	A
Phenol (Molten)		C	B	B	D	D	D	C	D	D	D	A	A	*	B	*	*	*
Phosphoric Acid Aq.	0.3	A	A	A	*	B	C	A	A	A	A	A	A	A	A	A	*	B
	3	A	A	A	D	C	C	A	A	A	A	A	A	A	A	A	*	C
	10	A	A	A	D	D	D	B	A	A	A	A	A	A	A	A	*	C
Phthalic Acid Aq.	SAT	C	A	A	B	B	A	*	*	*	*	A	A	*	A	*	*	*
Phthalic Dioctyl		*	*	*	A	A	*	*	*	*	*	A	*	A	A	*	*	*
Potassium Acetate Aq.	50	A	A	A	A	A	A	*	*	*	*	A	A	*	A	A	*	*
Potassium Bicarbonate Aq.	60	A	A	A	A	A	A	A	*	*	*	A	A	A	A	A	*	*
Potassium Bromide Aq.	10	A	A	A	A	A	A	A	A	*	*	A	A	A	A	A	*	*
Potassium Carbonate Aq.	60	A	A	A	A	A	A	A	*	*	A	A	A	A	A	A	*	*
Potassium Chloride Aq.	90	A	A	A	A	A	A	A	A	*	*	A	A	A	A	A	*	*
Potassium Dichromate Aq.	5	A	A	A	C	B	A	A	A	*	*	A	A	A	A	A	*	*
Potassium Ferricyanide Aq.	30	A	A	A	A	B	*	A	*	*	*	A	A	*	A	*	*	*
Potassium Ferrocyanide Aq.	30	A	A	A	A	B	*	*	*	*	*	A	A	*	A	*	*	*
Potassium Hydroxide Aq.	10	A	A	A	C	A	A	C	C	A	A	B	A	A	A	D	D	*
	50	A	A	A	C	A	D	C	D	B	*	C	A	A	A	D	*	*
Potassium Nitrate Aq.	10	A	A	A	A	A	B	A	A	A	*	A	A	A	A	*	*	*
Potassium Permanganate Aq.	1	B	A	A	D	C	A	A	A	A	*	A	A	A	A	A	*	*
Potassium Sulfite Aq.	CONC	A	A	A	A	A	*	*	*	*	*	A	A	A	A	A	*	*
Potassium Sulfite Aq.	90	A	A	A	A	*	*	*	*	*	*	A	A	*	A	A	*	*
Propane Gas		A	A	A	A	A	A	A	A	*	*	A	A	A	A	*	*	A
Pyridine		A	C	A	A	A	B	A	*	D	D	*	A	D	*	A	D	*
Resorcinol		A	B	*	D	D	*	*	*	*	*	A	A	*	A	*	*	*
Salicylic Acid		A	B	A	A	A	D	A	*	*	*	A	A	*	A	*	*	*
Silicone Fluids		A	A	A	A	A	A	A	A	*	*	A	A	A	A	A	B	A
Silver Nitrate		B	B	A	A	A	A	A	A	*	*	A	A	A	A	A	*	*
Soap Solutions		A	A	B	A	A	A	A	A	A	A	A	A	A	A	A	*	A
Sodium (Molten)		*	*	*	*	*	C	*	*	*	*	B	*	*	D	*	*	*
Sodium Acetate Aq.	60	A	A	A	A	B	A	A	*	*	*	A	A	A	A	A	*	*
Sodium Benzoate Aq.	10	A	A	A	A	*	A	A	*	*	*	A	A	*	A	A	*	*
Sodium Bicarbonate Aq.	50	A	A	A	A	A	A	A	A	*	*	A	A	A	A	A	*	*
Sodium Bisulfite Aq.	10	A	A	A	A	A	D	A	A	*	*	A	A	A	A	A	*	*
Sodium Bromide Aq.	10	A	A	*	A	B	A	A	*	*	*	A	A	A	A	A	*	*
Sodium Carbonate Aq.	20	A	A	A	A	B	A	A	*	*	*	A	A	A	A	A	*	A
	50	A	A	A	A	*	A	*	*	*	*	A	A	A	A	A	*	*
Sodium Chlorate Aq.	10	A	A	A	A	B	A	*	A	*	*	A	A	A	A	A	*	*
Sodium Chloride Aq.	10	A	A	A	A	B	A	A	A	A	*	A	A	A	A	A	*	*
	90	A	A	A	A	B	A	A	A	*	*	A	A	A	A	A	*	*
Sodium Cyanide Aq.	10	A	A	A	A	*	A	*	A	*	*	A	A	A	A	*	*	*
Sodium Hydroxide Aq.	10	B	B	A	C	D	D	C	C	A	A	B	A	A	A	D	*	B

The chemical resistance of plastics can be difficult to predict. It is dependent upon: temperature, time of exposure, chemical concentration, and stress on the material. Increases in any of these factors may result in reduced chemical inertness. This table is intended as a guide only, and not intended as an alternative to actual testing. Quadrant recommends actual testing which represents the only method for evaluating suitability for use.

Chemical	Concentration Weight, %	PROTEUS® PP	PROTEUS® HDPE / LDPE	TIVAR® UHMM-PE	Nylons		Acetron® GP POM-C, Acetron® POM-H	Ertalyte® PET-P	Ertalyte® TX PET-P	Quadrant PC 1000	Quadrant PSU	Duratron® U1000 PEI	Fluorosint® PTFE	SYMALIT® PVDF / ECTFE	Techtron® PPS	Ketron® 1000 PEEK	Duratron® PAI	Duratron® PI	Duratron® CU60 PBI
					Nylatron® PA66	Nylatron® PA6													
Sodium Hydroxide Aq.	50	B	B	A	D	D	D	C	D	C	D	C	A	B	A	A	D	*	C
Sodium Hypochlorite 15% Cl (Chlorine Bleach)		B	B	A	D	C	D	A	A	A	*	*	A	B	A	A	A	*	B
Sodium Nitrate Aq.	50	A	A	A	A	A	A	A	C	*	*	*	A	A	A	A	*	*	*
Sodium Perborate Aq.	10	A	A	A	B	*	A	*	*	*	*	*	A	A	*	A	*	*	*
Sodium Phosphate Aq.	90	A	A	A	A	*	*	*	*	*	*	*	A	A	*	A	*	*	*
Sodium Silicate		A	A	A	A	A	*	A	A	B	*	*	A	A	A	A	*	*	*
Sodium Sulfate Aq.	90	A	A	A	A	A	*	A	A	*	*	*	A	A	A	A	A	*	*
Sodium Sulfide Aq.	90	A	A	A	A	*	*	B	*	*	*	*	A	B	A	A	A	*	*
Sodium Thiosulfate Aq.	10	A	A	A	A	A	A	A	A	A	*	*	A	A	A	A	*	*	*
Stannic Chloride Aq.	10	A	A	*	D	*	D	*	A	A	A	A	A	A	A	A	*	*	A
Stannic Sulfate Aq.	10	*	*	*	D	C	*	*	*	*	*	*	A	*	A	A	*	*	*
Stearic Acid		B	A	A	A	A	A	*	*	*	*	*	A	A	*	A	*	*	*
Styrene (Monomer)		B	B	B	A	A	A	C	D	*	*	*	A	A	A	A	*	*	*
Sulfur		A	A	A	A	A	A	A	A	*	*	*	A	A	*	A	*	*	*
Sulfur Dioxide (Dry Gas)	100	B	A	A	C	A	D	B	A	*	*	*	A	B	A	A	A	*	*
Sulfuric Acid Aq.	2	A	A	A	C	C	D	A	A	A	A	A	A	B	A	A	A	B	B
	5	A	A	A	D	D	D	A	A	A	A	A	A	B	A	A	A	B	B
Sulfuric Acid Conc.	96	B	B	B	D	D	D	C	D	D	D	D	A	B	B	D	*	C	*
Sulfurous Acid Aq.	10	A	A	A	A	*	D	*	A	A	A	A	A	B	A	A	*	*	B
Tallow		A	B	A	A	A	A	*	A	A	A	A	A	A	A	A	A	*	A
Tar		A	A	A	B	B	A	*	*	*	*	*	A	A	A	A	A	*	*
Tartaric Acid Aq.	10	A	A	A	B	A	A	*	A	*	*	*	A	A	A	A	*	*	*
Tetrachlorethylene		C	B	B	A	C	A	B	D	D	A	B	B	*	A	*	*	*	
Tetrahydrofuran		D	D	B	A	A	B	A	D	*	*	*	A	B	A	A	A	*	A
Tetralin		C	C	*	A	A	A	A	*	*	*	*	A	*	*	A	*	*	*
Thionyl Chloride		C	C	C	D	C	B	*	*	*	*	*	A	B	*	A	*	*	*
Thiophene		B	C	B	A	*	*	*	D	*	*	*	A	*	*	A	*	*	*
Toluene		B	B	B	A	A	B	A	D	D	D	A	A	A	A	A	A	*	A
Transformer Oil		B	B	B	A	A	A	*	A	A	*	*	A	A	A	A	A	A	*
Trichlorethylene		D	D	D	B	B	D	B	D	D	D	A	A	A	A	A	A	*	*
Triethanolamine		D	D	A	A	A	A	B	D	C	D	A	B	A	A	A	D	*	*
Turpentine		C	D	B	A	A	A	*	B	C	*	*	A	A	A	A	A	*	*
Trisodium Phosphate Aq.	95	A	A	A	*	B	A	A	A	*	*	*	A	A	A	A	*	*	*
Urea		A	A	A	A	A	A	A	A	*	*	*	A	A	A	A	*	*	*
Vaseline		A	A	A	A	A	A	A	A	A	A	A	A	A	A	A	A	*	A
Vegetable Oils		B	B	A	A	A	A	A	A	A	A	A	A	A	A	A	A	*	A
Vinegar		A	A	A	C	C	B	A	A	*	*	*	A	B	A	A	A	*	A
Vinyl Chloride		A	A	A	A	A	*	*	*	*	*	*	A	A	A	A	*	*	*
Water		A	A	A	A	A	A	A	A	A	A	A	A	A	A	A	A	*	A
Water (Mildly Chlorinated)	<10	A	A	A	A	A	C	A	A	A	A	A	A	A	A	A	A	A	A
Wax (Molten)		B	A	A	A	A	A	A	A	A	A	A	A	A	A	A	A	*	A
White Spirit		A	A	A	A	A	A	*	*	*	*	*	A	A	A	A	*	*	*
Wines & Spirits		A	A	A	B	B	A	A	A	*	*	A	A	A	A	A	A	*	A
Xylene		B	C	C	A	A	A	A	D	D	C	A	A	A	A	A	A	*	A
Xylenol		*	*	*	D	D	A	*	D	D	B	A	*	*	*	A	A	*	A
Zinc Chloride Aq.	10	A	A	A	C	B	D	A	A	A	A	A	A	A	A	A	*	*	*
Zinc Oxide		A	A	*	A	A	C	*	*	*	*	*	A	A	A	A	*	*	*
Zinc Sulfate Aq.	10	A	A	A	A	*	C	*	A	*	*	*	A	A	A	A	*	*	*

KEY:

- A No attack, possibly slight absorption. Negligible effect on mechanical properties
- B Slight attack by absorption, some swelling and a small reduction in mechanical properties likely
- C Moderate attack or appreciable absorption; material will have limited life
- D Material will decompose or dissolve in a short time

* No data available

Aq. Aqueous Solution

SAT Saturated Aqueous Solution

CONC Concentrated Aqueous Solution

Where aqueous solutions are shown, the concentration as a percentage of weight is given.

PRODUCT COMPLIANCE

Quadrant materials are commonly used in processing equipment and products requiring various types of regulatory agency compliance. We routinely work with these agencies to assure the widest variety of our products are recognized as being compliant – giving designers the broadest selection of candidate materials.

A brief overview of the six most common agencies is provided below. Additionally, we have specific product listings with Underwriters Laboratories (UL), American Bureau of Shipping (ABS), ASTM and many global manufacturers.

Quadrant can work with customers to develop unique product / quality specifications requiring testing, inspection and certifications. Such requests should be directed to Quadrant Engineering Plastic at 1-800-366-0310.

FDA

FDA (Food & Drug Administration) takes responsibility for determining whether and how manufactured materials may be used in contact with food products. Definitions for proper use are found in a series of regulations published annually under Government Regulations CFR 21. The FDA provides certain specifications regarding composition, additives, and properties. A material which meets these standards can then be stated as FDA COMPLIANT. End-users should note that it is their responsibility to use the product in a manner compatible with FDA guidelines.

USDA

USDA (U.S. Department of Agriculture) has jurisdiction over equipment used in federally inspected meat and poultry processing plants, and over packaging materials used for such products. Materials used in this equipment are approved on an individual basis. Determining suitability for use of components and the materials from which they are made is the responsibility of the equipment manufacturer. Supporting documentation as may be required by the Food Safety Inspection Service of USDA, is available.

CFIA

Health Canada and CFIA (Canadian Food Inspection Agency) are agency equivalents to the FDA and USDA. Health Canada, similar to FDA, takes responsibility for determining policies, standards, and regulations for ensuring safe food supply. CFIA, similar to USDA, enforces policies, regulations, and standards set by Health Canada. CFIA has jurisdiction over federally registered establishments AND reviews safety of finished articles used in these facilities. As with the USDA, plastic materials are approved per material for a group of related applications, such as Acetron® GP POM-C acetal (material) for meat and poultry processing (application).

3A-SSI

3A-SSI (Sanitary Standards, Inc.) is a voluntary organization that provides standards of construction for milk, cheese, butter and ice cream processing equipment.

The organization covers the requirements of plastic materials for multiple-use as product contact surfaces in equipment for production, processing, and handling of food products. The criteria for approval of plastic materials are specified in 3A standard 20-18, and include: cleanability, bacterial treatment, repeat use conditions, and FDA compliance. Materials are tested for compliance by the material supplier. Supporting documentation must be available as required by a food inspector.

NSF

NSF (National Sanitation Foundation) sets standards for food, water, indoor air and environment. Manufacturers who provide equipment displaying the NSF symbol have applied to the NSF for device approval to a specific standard. The approval is issued for the finished product (device) in a specific use (application). To obtain device approval, the device must comply with the appropriate STANDARD by meeting material, design, construction, and performance criteria.

The NSF maintains numerous standards. Two standards which we frequently encounter and to which some of our products have been tested are:

- 51 Plastics in Food Equipment
- 61 Drinking Water System Components – Health Effects

USP Class VI

USP (U.S. Pharmacopoeia) Class VI judges the suitability of plastic material intended for use as containers or accessories for parenteral preparations. Suitability under USP Class VI is typically a base requirement for medical device manufacturers.

Quadrant stock shapes are not suitable for permanent implant.

Quadrant produces a line of Life Science Grade (LSG) materials for which the stock shape has been tested to USP Class VI and ISO 10993 guidelines. These products are appropriate for applications requiring implant for up to 24 hours.

MATERIAL	Product Family	COLOR	FDA	USDA	NSF	3A-DAIRY	CANADA AG	USP CLASS VI ^A	Typical Applications (Structural or Wear)
Acetron® GP POM-C	Acetal	Nat / Blk	YES	YES	STD 51 & 61 (Natural Only)	YES	YES	NO	Both
Quadrant CPVC	CPVC	Grey	NO	NO	STD 14 & 61	NO	NO	NO	Structural
Acetron® POM-H	Acetal	Natural	YES	YES	STD 61 & 51	NO	YES	NO	Both
Acetron® AF Blend PTFE	Acetal	Brown	NO	NO	NO	NO	NO	NO	Bearing & Wear
Ertalyl® PET-P	Polyester	Natural	YES	YES	NO	YES	YES	NO	Both
Ertalyl® PET-P	Polyester	Black	YES	YES	NO	NO	NO	NO	Both
Ertalyl® TX PET-P	Polyester	Grey	YES	YES	NO	YES	NO	NO	Both
Fluorosint® 207 PTFE	PTFE	Natural	YES	YES	NO	NO	NO	NO	Bearing & Wear
Fluorosint® 500 PTFE	PTFE	Natural	NO	NO	NO	NO	NO	NO	Both
Fluorosint® HPV PTFE	PTFE	Natural	YES	-	NO	NO	NO	NO	Both
PROTEUS® HDPE	HDPE	Natural	YES	YES	NO	NO	NO	NO	Both
Ketron® 1000 PEEK	PEEK	Natural	YES	YES	NO	NO	NO	NO	Both
PROTEUS® LDPE	LDPE	Natural	YES	YES	NO	YES	NO	NO	Both
MC® 901 PA6	Nylon 6	Blue	NO	NO	NO	NO	NO	NO	Structural
MC® 907 PA6	Nylon 6	Natural	YES	YES	NO	YES	NO	NO	Both
Quadrant PPO	PPO	Black	NO	NO	STD 61	NO	NO	NO	Structural
Nylatron® GS PA66	Nylon 66	Black-Grey	NO	NO	NO	NO	NO	NO	Both
Nylatron® GSM PA6	Nylon 6	Black-Grey	NO	NO	NO	NO	NO	NO	Bearing & Wear
Nylatron® GSM Blue PA6	Nylon 6	Dark Blue	NO	NO	NO	NO	NO	NO	Bearing & Wear
Nylatron® NSM PA6	Nylon 6	Grey	NO	NO	NO	NO	NO	NO	Bearing & Wear
Nylatron® LFG PA6	Nylon 6	Natural	YES	NO	NO	YES	NO	NO	Bearing & Wear
Quadrant Nylon 101 PA66	Nylon 66	Natural	YES	YES	STD 61	YES	NO	NO	Both
Quadrant PC 1000	PC	Natural	NO	NO	NO	NO	NO	NO	Structural
Quadrant PSU	PSU	Natural	YES	YES	STD 61	YES	NO	YES	Structural
PROTEUS® Homopolymer Polypropylene (APPROVED)	PP	Natural	YES	YES	STD 2 & 51	YES	NO	YES	Structural
PROTEUS® White Polypropylene	PP	White	YES	NO	NO	NO	NO	NO	Structural
PROTEUS® CoPolymer Polypropylene	CO-PP	Natural	YES	NO	NO	YES	NO	NO	Structural
Quadrant PPSU (Natural & Black)	PPSU	Natural	YES	NO	NO	NO	NO	YES	Structural
Sanalite® Cutting Board-HDPE or PP (APPROVED)	HDPE	Natural	YES	YES	STD 2 & 51	NO	YES	NO	Structural
PP	PP	Natural	YES	YES	NO	YES	NO	YES	Structural
SYMALIT® PVDF (Kymar)	PVDF	Natural	YES	YES	NO	YES	NO	YES	Structural
Techtron® 1000 PPS	PPS	Natural	YES	NO	NO	YES	NO	NO	Structural
TIVAR® 1000 UHMW-PE	UHMW-PE	Natural	YES	YES	NO	YES	YES	NO	Bearing & Wear
TIVAR® H.O.T. UHMW-PE	UHMW-PE	White	YES	YES	NO	YES	NO	NO	Bearing & Wear
TIVAR® Oil-Filled UHMW-PE	UHMW-PE	Brown/Grey	YES	YES	NO	NO	NO	NO	Bearing & Wear
TIVAR® CleanStat UHMW-PE	UHMW-PE	Black	YES	YES	NO	YES	NO	NO	Bearing & Wear
Duratron® U1000 PEI*	PEI	Natural	YES	YES	STD 51	NO	NO	YES	Structural
Duratron® U1000 PEI*	PEI	Black	YES	YES	NO	NO	YES	YES	Structural

Table 16

Duratron® CU60 PBI, Duratron® PAI and all fiber-reinforced (i.e. glass, carbon) materials available from Quadrant are neither FDA, USDA nor 3A-Dairy compliant.

^A No Quadrant Engineering Plastic Products' materials are suitable for permanent implantable devices.

[FABRICATION GUIDELINES

The following guidelines are presented for those machinists not familiar with the machining characteristics of plastics. They are intended as guidelines only, and may not represent the most optimum conditions for all parts. The troubleshooting quick reference on page 42 should be used to correct undesirable surface finishes or material responses during machining operations.

All Quadrant materials are stress relieved to ensure the highest degree of machinability and dimensional stability. However, the relative softness of plastics (compared to metals) generally results in greater difficulty maintaining tight tolerances during and after machining. A good rule of thumb for tolerances of plastic parts is $\pm .001$ " per inch of dimension although tighter tolerances are possible with very stable, reinforced materials.

When machining Quadrant stock shapes, remember...

- **Thermal expansion is up to 10 times greater with plastics than metals**
- **Plastics lose heat more slowly than metals, so avoid localized overheating**
- **Softening (and melting) temperatures of plastics are much lower than metals**
- **Plastics are much more elastic than metals**
Because of these differences, you may wish to experiment with fixtures, tool materials, angles, speeds and feed rates to obtain optimum results.

Getting Started

- **Positive tool geometries with ground peripheries are recommended**
- **Carbide tooling with polished top surfaces is suggested for optimum tool life and surface finish. Polycrystalline diamond tooling provides optimum surface finish when machining Duratron® CU60 PBI.**
- **Use adequate chip clearance to prevent clogging**
- **Adequately support the material to restrict deflection away from the cutting tool**

Coolants

Coolants are generally not required for most machining operations (not including drilling and parting off). However, for optimum surface finishes and close tolerances, non-aromatic, water soluble coolants are suggested. Spray mists and pressurized air are very effective means of cooling the cutting interface. General purpose petroleum based cutting fluids, although suitable for many metals and plastics, may contribute to stress cracking of amorphous plastics such as Quadrant PC 1000, Quadrant PSU, Duratron® U1000 PEI, and Quadrant PPSU.

MACHINING TIPS

- Coolants are strongly suggested during drilling operations, especially with notch sensitive materials such as Ertalyte® PET-P, Duratron® PAI, Duratron® CU60 PBI and glass or carbon reinforced products.
- In addition to minimizing localized part heat-up, coolants prolong tool life. Two (flood) coolants suitable for most plastics are Trim E190 and Trim Sol LC SF (Master Chemical Corporation-Perrysburg, OH).

Turning

Turning operations require inserts with positive geometries and ground peripheries. Ground peripheries and polished top surfaces generally reduce material build-up on the insert, improving the attainable surface finish. A fine grained C-2 carbide is generally best for turning operations.

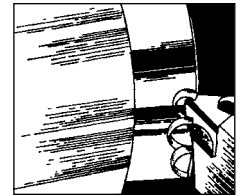

Drilling

The insulating characteristics of plastics require consideration during drilling operations, especially when hole depths are greater than twice the diameter.

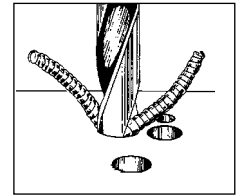

Small diameter holes (1/32" to 1" diameter)

High speed steel twist drills are generally sufficient for small holes. To improve swarf removal, frequent pull-out (peck drilling) is suggested. A slow spiral (low helix) drill will allow for better swarf removal.

Large diameter holes (1" diameter and larger)

A slow spiral (low helix) drill or general purpose drill bit ground to a 118° point angle with 9° to 15° lip clearance is recommended. The lip rake should be ground (dubbed off) and the web thinned.

It is generally best to drill a pilot hole (maximum 1/2" diameter) using 600 to 1,000 rpm and a positive feed of 0.005" to 0.015" per revolution. Avoid hand feeding because of the drill grabbing which can result in microcracks forming. Secondary drilling at 400 to 500 rpm at 0.008" to 0.020" per revolution is required to expand the hole to larger diameters.

A two step process using both drilling and boring can be used on notch sensitive materials such as Ertalyte® PET-P and glass reinforced materials. This minimizes heat build-up and reduces the risk of cracking.

1. Drill a 1" diameter hole using an insert drill at 500 to 800 rpm with a feed rate of 0.005" to 0.015" per revolution.
2. Bore the hole to final dimensions using a boring bar with carbide insert with 0.015" to 0.030" radii at 500 to 1,000 rpm and a feed rate of 0.005" to 0.010" per revolution.



Table 17 : Fabrication Guidelines for All Quadrant Materials Turning and Drilling Operations

Material	Relative Machinability (1 to 10 1=easiest)	Turning			Drilling**	
		Depth of Cut	Speed Feet/Min.	Feed, In./Rev.	Nominal Hole Diameter	Feed, In./Rev.
TIVAR® UHMW-PE, Nylatron® PA, Acetron® POM based materials	1 - 2	.150" deep cut .025" deep cut	500-600 600-700	.010-.015 .004-.007	1/16" to 1/4" 1/2" to 3/4" 1" to >2"	.007-.015 .015-.025 .020-.050
PROTEUS®PP, Quadrant PC 1000, Quadrant PSU, Quadrant PPSU, & Duratron® PEI based materials	2 - 3	.150" deep cut .025" deep cut	500-600 600-700	.010-.015 .004-.007	1/16" to 1/4" 1/2" to 3/4" 1" to >2"	.007-.015 .015-.025 .020-.050
Ertalyte® PET-P based materials	2	.150" deep cut .025" deep cut	500-600 600-700	.010-.015 .004-.007	1/16" to 1/4" 1/2" to 3/4" 1" to >2"	.002-.005 .015-.025 .020-.050
SYMALIT® PVDF & ECTFE based materials	2	.150" deep cut .025" deep cut	500-600 600-700	.010-.015 .004-.007	1/16" to 1/4" 1/2" to 3/4" 1" to >2"	.002-.005 .015-.025 .020-.050
Ketron® PEEK based materials	5 - 7	.150" deep cut .025" deep cut	350-500 500-600	.010-.015 .003-.008	1/16" to 1/4" 1/2" to 3/4" 1" to >2"	.002-.005 .004-.008 .008-.012
Fluorosint® PTFE(1) based materials	1 - 3	.150" deep cut .025" deep cut	600-1000 600-700	.010-.016 .004-.007	1/16" to 1/4" 1/2" to 3/4" 1" to >2"	.007-.015 .015-.025 .020-.050
Techtron® PPS based materials	5	.150" deep cut .025" deep cut	100-300 250-500	.010-.020 .005-.010	1/16" to 1/4" 1/2" to 3/4" 1" to >2"	.007-.015 .015-.025 .020-.050
Duratron® PAI & Duratron® PI based materials	5 - 8	.025" deep cut	300-800	.004-.025	1/16" to 1/4" 1/2" to 3/4" 1" to >2"	.007-.015 .015-.025 .020-.050
Duratron® CU60 PBI based materials	10	.025" deep cut	150-225	.002-.006	1/2" or larger	.015-.025

** The recommended speed for drilling operations is 150 to 200 ft./min.

(1) For Fluorosint® MT-01, contact Quadrant's Technical Service Team

[FABRICATION GUIDELINES

Threading and Tapping

Threading should be done by single point using a carbide insert and taking four to five 0.001" passes at the end. Coolant usage is suggested. For tapping, use the specified drill with a two flute coated tap. Remember to keep the tap clean of chip build-up. Use of a coolant during tapping is also suggested. Use of a coated tap will create radii at the root of the threads resulting in a stronger and tougher thread which is less prone to cracking from over-torquing.

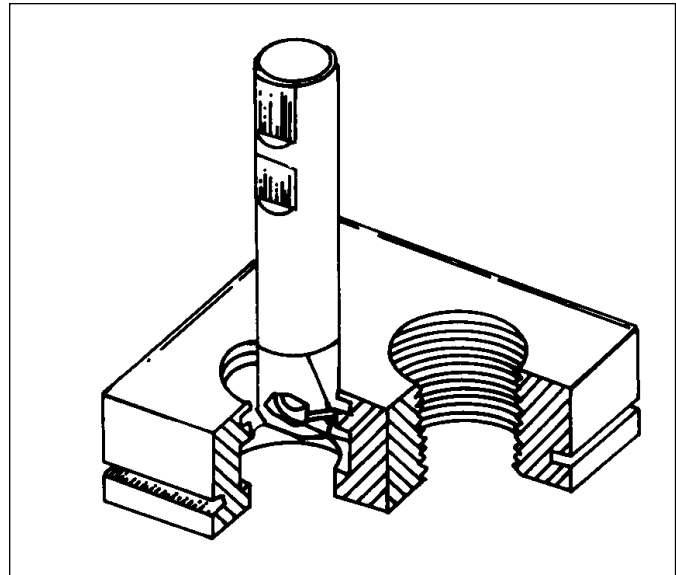
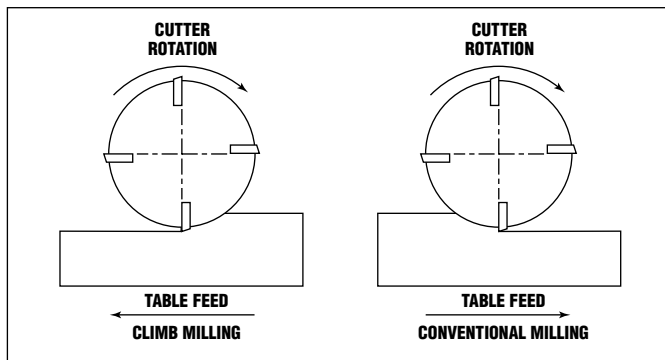

Milling

Sufficient fixturing allows fast table travel and high spindle speeds when end milling plastics. When face milling, use positive geometry cutter bodies. Climb milling is recommended over conventional milling.

Sawing

Band sawing is versatile for straight, continuous curves or irregular cuts. Table saws are convenient for straight cuts and can be used to cut multiple thicknesses and thicker cross sections up to 4" with adequate horsepower. Saw blades should be selected based upon material thickness and surface finish desired.

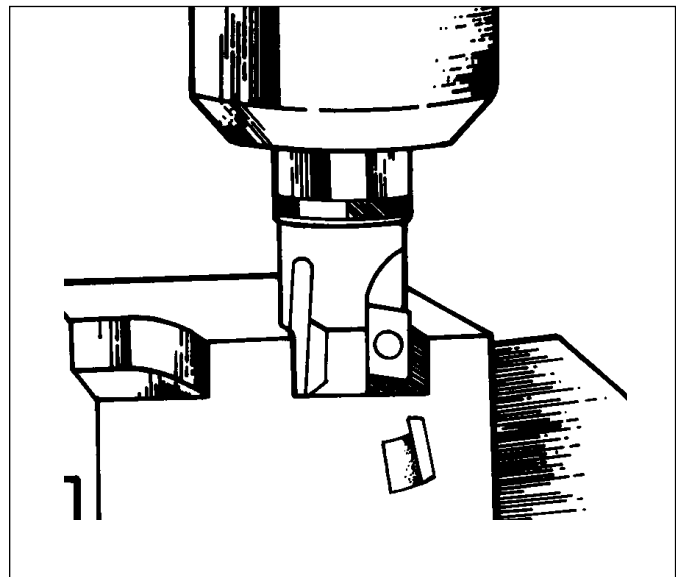

SAWING TIPS

- Rip and combination blades with a 0° tooth rake and 3° to 10° tooth set are best for general sawing in order to reduce frictional heat.
- Hollow ground circular saw blades without set will yield smooth cuts up to 3/4" thickness.
- Tungsten carbide blades wear well and provide optimum surface finishes.

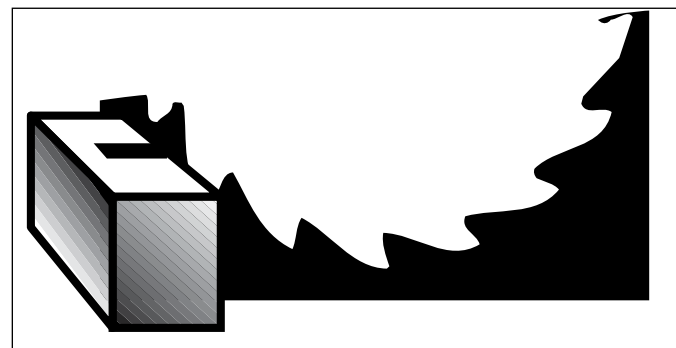

Table 18 : Fabrication Guidelines—Milling and Sawing

	End Milling / Slotting				Face Milling (C-2) Carbide Tool			Sawing			
	High Speed Steel (M2, M7)	Depth of Cut	Speed, Ft./Min.	Feed, In./Min.	Depth of Cut	Speed, Ft./Min.	Feed, In./Min.	Material Thickness	Tooth Form	Pitch Teeth/In.	Band Speeds Ft./Min.
TIVAR® UHMW-PE, Nylatron® PA, Acetron® POM based materials	1/4"	0.250	270-450	0.002	0.150	1300-1500	0.020	<.5"	Precision	10-14	3,000
	1/2"	"	"	0.003	0.060	1500-2000	0.005	.5"-1.0"	"	6	2,500
	3/4"	"	"	0.005				1.0-3.0"	Butress	3	2,000
	1", 2"	"	"	0.008				>3.0"	"	3	1,500
	1/4"	0.050	300-500	0.001							
	1/2"	"	"	0.002							
	3/4"	"	"	0.004							
PROTEUS® PP, Quadrant PC 1000, Quadrant PSU, Quadrant PPSU, & Duratron® PEI based materials	1/4"	0.250	270-450	0.002	0.150	1300-1500	0.020	<.5"	Precision	10-14	4,000
	1/2"	"	"	0.003	0.060	1500-2000	0.005	.5"-1.0"	"	6	3,500
	3/4"	"	"	0.005				1"-3"	Butress	3	3,000
	1", 2"	"	"	0.008				>3"	"	"	2,500
	1/4"	0.050	300-500	0.001							
	1/2"	"	"	0.002							
	3/4"	"	"	0.004							
Ertalyte® PET-P based materials	1/4"	0.250	270-450	0.002	0.150	1300-1500	0.020	<.5"	Precision	10-14	5,000
	1/2"	"	"	0.003	0.060	1500-2000	0.005	.5"-1.0"	"	6	4,300
	3/4"	"	"	0.005				1"-3"	Butress	3	3,500
	1", 2"	"	"	0.008				>3"	"	"	3,000
	1/4"	0.050	300-500	0.001							
	1/2"	"	"	0.002							
	3/4"	"	"	0.004							
SYMALIT® PVDF & ECTFE based materials	1/4"	0.250	270-450	0.002	0.150	1300-1500	0.020	<.5"	Precision	10-14	4,000
	1/2"	"	"	0.003	0.060	1500-2000	0.005	.5"-1.0"	"	6	3,500
	3/4"	"	"	0.005				1"-3"	Butress	3	3,000
	1", 2"	"	"	0.008				>3"	"	"	2,500
	1/4"	0.050	300-500	0.001							
	1/2"	"	"	0.002							
	3/4"	"	"	0.004							
Ketron® PEEK based materials	1/4"	0.150	500-750	0.002	0.150	500-750	0.020	<.5"	Precision	10-14	4,000
	1/2"	"	"	"	0.060		0.005	.5"-1.0"	"	6-8	3,500
	3/4"	"	"	"				1"-3"	Butress	3	3,000
	1", 2"	"	"	"				>3"	"	"	2,500
	1/4"	0.060	"	0.005							
	1/2"	"	"	"							
	3/4"	"	"	"							
Fluorosint® PTFE ⁽¹⁾ based materials	1/4"	0.150	500-700	0.010	0.150	500-700	0.010	<.5"	Precision	10-14	3,000
	1/2"	"	"	"	0.060	550-750	0.005	.5"-1.0"	"	6-8	2,500
	3/4"	"	"	"				1"-3"	Butress	3	2,000
	1", 2"	"	"	"				>3"	"	"	1,500
	1/4"	0.060	550-750	0.005							
	1/2"	"	"	"							
	3/4"	"	"	"							
Techtron® PPS based materials	1/4"	0.150	1300-1500	0.020	0.150	1300-1500	0.020	<.5"	Precision	10-14	5,000
	1/2"	"	"	"	0.060	1500-2000	0.005	.5"-1.0"	"	6-8	4,300
	3/4"	"	"	"				1"-3"	Butress	3	3,500
	1", 2"	"	"	"				>3"	"	"	3,000
	1/4"	0.060	1500-2000	0.005							
	1/2"	"	"	"							
	3/4"	"	"	"							
Duratron® PAI & Duratron® PI based materials	1/2"	0.035	500-800	0.006	0.035	500-800	.006-.035	<.5"	Precision	10-14	5,000
	3/4"	"	"	"				.5"-1.0"	"	6-8	4,300
	1", 2"	"	"	to				1"-3"	Butress	3	3,500
	1/4"	"	"	"				>3.0"	"	"	3,000
	1/2"	"	"	0.035							
	3/4"	"	"	"							
Duratron® CU60 PBI	1/4"	0.015	250-350	0.002	0.015	250-350	.002-.006	.375"-1"	Precision	10	3,000
	1/2"	"	"	"							
	3/4"	"	"	to				1"-2"	Butress	10	1,500
	1", 2"	"	"	"							
	1/4"	"	"	"							
	1/2"	"	"	0.006							
	3/4"	"	"	"							

[FABRICATION GUIDELINES

Table 19 : Troubleshooting Quick Reference

Drilling	
Difficulty	Common Cause
Tapered hole	<ol style="list-style-type: none"> 1. Incorrectly sharpened drill 2. Insufficient clearance 3. Feed too heavy
Burnt or melted surface	<ol style="list-style-type: none"> 1. Wrong type drill 2. Incorrectly sharpened drill 3. Feed too light 4. Dull drill 5. Web too thick 6. Not peck drilling
Chipping of surfaces	<ol style="list-style-type: none"> 1. Feed too heavy 2. Clearance too great 3. Too much rake (thin web as described)
Chatter	<ol style="list-style-type: none"> 1. Too much clearance 2. Feed light 3. Drill overhang too great 4. Too much rake (thin web as described)
Feed marks or spiral lines on inside diameter	<ol style="list-style-type: none"> 1. Feed too heavy 2. Drill not centered 3. Drill ground off-center
Oversize holes	<ol style="list-style-type: none"> 1. Drill ground off-center 2. Web too thick 3. Insufficient clearance 4. Feed rate too heavy 5. Point angle too great
Undersize holes	<ol style="list-style-type: none"> 1. Dull drill 2. Too much clearance 3. Point angle too small
Holes not concentric	<ol style="list-style-type: none"> 1. Feed too heavy 2. Spindle speed too slow 3. Drill enters next piece too far 4. Cut-off tool leaves nib, which deflects drill 5. Web too thick 6. Drill speed too heavy at start 7. Drill not mounted on center 8. Drill not sharpened correctly
Burr at cut-off	<ol style="list-style-type: none"> 1. Dull cut-off tool 2. Drill does not pass completely through piece
Rapid dulling of drill	<ol style="list-style-type: none"> 1. Feed too light of drill 2. Spindle speed too fast 3. Insufficient lubrication from coolant

Cutting Off	
Difficulty	Common Cause
Melted surface	<ol style="list-style-type: none"> 1. Dull tool 2. Insufficient side clearance 3. Insufficient coolant supply
Rough finish	<ol style="list-style-type: none"> 1. Feed too heavy 2. Tool improperly sharpened 3. Cutting edge not honed
Spiral marks	<ol style="list-style-type: none"> 1. Tool rubs during its retreat 2. Burr on point of tool
Concave or convex surfaces	<ol style="list-style-type: none"> 1. Point angle too great 2. Tool not perpendicular to spindle 3. Tool deflecting 4. Feed too heavy 5. Tool mounted above or below center
Nibs or burrs at cut-off point	<ol style="list-style-type: none"> 1. Point angle not great enough 2. Tool dull 3. Feed too heavy
Burrs on outside diameter	<ol style="list-style-type: none"> 1. No chamfer before cut-off diameter 2. Dull tool

Turning & Boring	
Difficulty	Common Cause
Melted surface	<ol style="list-style-type: none"> 1. Tool dull or heel rubbing 2. Insufficient side clearance 3. Feed rate too slow 4. Spindle speed too fast
Rough finish	<ol style="list-style-type: none"> 1. Feed too heavy 2. Incorrect clearance angles 3. Sharp point on tool (slight nose radius required) 4. Tool not mounted on center
Burrs at edge of cut	<ol style="list-style-type: none"> 1. No chamfer provided at sharp corners 2. Dull tool 3. Insufficient side clearance 4. Lead angle not provided on tool (tool should ease out of cut gradually, not suddenly)
Cracking or chipping of corners	<ol style="list-style-type: none"> 1. Too much positive rake on tool 2. Tool not eased into cut (tool suddenly hits work) 3. Dull tool 4. Tool mounted below center 5. Sharp point on tool (slight nose radius required)
Chatter	<ol style="list-style-type: none"> 1. Too much nose radius on tool 2. Tool not mounted solidly 3. Material not supported properly 4. Width of cut too wide (use 2 cuts)

>> POST MACHINING

ANNEALING

When should parts be annealed after machining to ensure optimum part performance?

Experience has shown us that very few machined plastic parts require annealing after machining to meet dimensional or performance requirements.

All Quadrant stock shapes are annealed using a proprietary stress relieving cycle to minimize any internal stresses that may result from the manufacturing process. This assures you that the material will remain dimensionally stable during and after machining.

Machined-in stress can reduce part performance and lead to premature part failure. To prevent machined-in stress, it is important to identify the causes.

Machined-in stress is created by:

- **Using dull or improperly designed tooling**
- **Excessive heat – generated from inappropriate speeds and feed rates**
- **Machining away large volumes of material – usually from one side of the stock shape**

To reduce the potential for machined-in stress, review the fabrication guidelines for the specific material. Recognize that guidelines change as the material type changes.

Table 20 : Post Machining Air Annealing Guidelines*

Material	Heat Up*	Hold*	Cool Down*	Environment
Nylatron® PA6	4 hours to 300°F	30 minutes per 1/4" thickness	50°F per hour	Oil or Nitrogen
Nylatron® PA66	4 hours to 350°F	30 minutes per 1/4" thickness	50°F per hour	Oil or Nitrogen
Ertalyte® PET-P Grades	4 hours to 350°F	30 minutes per 1/4" thickness	50°F per hour	Oil or Nitrogen
Acetron® GP POM-C	4 hours to 310°F	30 minutes per 1/4" thickness	50°F per hour	Nitrogen or Air
Acetron® POM-H	4 hours to 320°F	30 minutes per 1/4" thickness	50°F per hour	Nitrogen or Air
Quadrant PC 1000	4 hours to 275°F	30 minutes per 1/4" thickness	50°F per hour	Air
Quadrant PSU	4 hours to 330°F	30 minutes per 1/4" thickness	50°F per hour	Air
Quadrant PPSU	4 hours to 390°F	30 minutes per 1/4" thickness	50°F per hour	Nitrogen or Air
Duratron® PEI	4 hours to 390°F	30 minutes per 1/4" thickness	50°F per hour	Nitrogen or Air
Techtron® PPS	4 hours to 350°F	30 minutes per 1/4" thickness	50°F per hour	Air
Ketron® PEEK (ramp up)	4 hours to 300°F 4 hours to 375°F	60 minutes per 1/4" thickness 60 minutes per 1/4" thickness	50°F per hour	Air
Duratron® PAI (ramp up)	4 hours to 300°F 4 hours to 420°F 4 hours to 470°F 4 hours to 500°F	1 day 1 day 1 day 3 to 10 days	50°F per hour	Air
Duratron® PI (ramp up)	4 hours to 300°F 4 hours to 450°F 4 hours to 600°F	60 minutes per 1/4" thickness 60 minutes per 1/4" thickness	50°F per hour	Air

Finish machining of critical dimensions should be performed after annealing.

* Temperatures +/- 10°F and times within 10 minutes

Benefits of Post-Machining Annealing

- **Improved Chemical Resistance**
Polycarbonate, polysulfone, and Duratron® PEI, like many amorphous (transparent) plastics may be annealed to minimize stress crazing. Duratron® PAI also benefits from post machining annealing. Annealing finished parts becomes more important as machining volume increases. Annealing after machining reduces “machined-in” stresses that can contribute to premature failure.
- **Better Flatness and Tighter Tolerance Capability**
Extremely close-tolerance parts requiring precision flatness and non-symmetrical contour sometimes require intermediate annealing between machining operations. Improved flatness can be attained by rough machining, annealing and finish machining with a very light cut. Balanced machining on both sides of the shape centerline can also help prevent warpage.
- **Improved Wear Resistance**
Extruded or injection molded Duratron® PAI parts that require high PV's or the lowest possible wear factor benefit from an additional cure after machining. This curing process optimizes the wear properties. Only Duratron® PAI benefits from such a cycle.

Important: Annealing cycles have been generalized to apply to a majority of machined parts. Changes in heat up and hold time may be possible if cross sections are thin. Parts should be fixtured during annealing to prevent distortion.

Distributed by:



Learn more online at
www.quadrantplastics.com

Quadrant has extensive product and machining resources available online. Our website is a portal to a wealth of technical data and the easiest way to engage our application specialists. Our team stands ready to help offer solutions to your toughest problems.

Quadrant Engineering Plastic Products Worldwide

EUROPE

Hardstrasse 5
CH-5600 Lenzburg
Tel +41 (0) 62 8858259
Fax +41 (0) 62 8858401
e-mail: info@qplas.com

NORTH AMERICA

2120 Fairmont Avenue
PO Box 14235 - Reading, PA 19612-4235
Tel 800 366 0300 / +1 610 320 6600
Fax 800 366 0301 / +1 610 320 6868
e-mail: americas.epp@qplas.com

ASIA-PACIFIC

60 Ha Mei San Tsuen, Ping Shan
YUEN LONG,
N.T. Hong Kong
Tel +852 (0) 24702683
Fax +852 (0) 24789966
e-mail: asia.epp@qplas.com

**BELGIUM • FRANCE • GERMANY • HONG KONG • HUNGARY • INDIA • ITALY • JAPAN • KOREA • MEXICO • POLAND
SOUTH AFRICA • SWITZERLAND • THE NETHERLANDS • UNITED KINGDOM • UNITED STATES OF AMERICA**

All statements, technical information and recommendations contained in this publication are presented in good faith, based upon tests believed to be reliable and practical field experience. The reader is cautioned, however, that Quadrant Engineering Plastic Products does not guarantee the accuracy or completeness of this information and it is the customer's responsibility to determine the suitability of Quadrant's products in any given application.

Acetron, Duraspin, Duratron, Erta, Ertacetal, Ertalene, Ertalon, Ertalyte, Extreme Materials, Fluorosint, Ketron, MC, Monocast, Novatron, Nylatrack, Nylatron, Polypenco, Proteus, Sanalite, Semitron, Symalit, Techtron, TIVAR, Ultrawear and Vibratuf are registered trademarks of the Quadrant group of companies.

*Classix is a registered trademark of Invibio Ltd. Corp.

*Rulon is a registered trademark of Saint Gobain Performance Plastics

*Torlon is a registered trademark of Solvay Advanced Polymers

*Vespel is a registered trademark of E.I. DuPont



QUADRANT

This guide was created by Quadrant Engineering Plastic Products.
Design and content are protected by copyright law.
Copyright © 2011 The Quadrant group of companies. All rights reserved.